

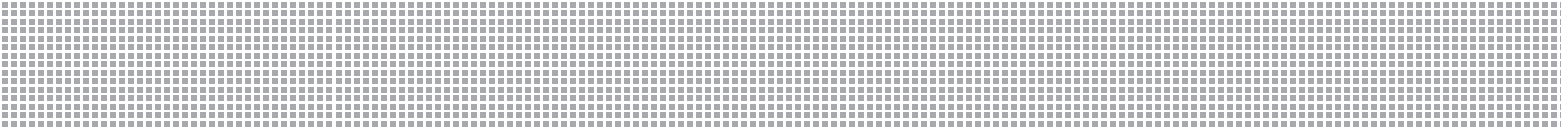

Expertise Applied | Answers Delivered

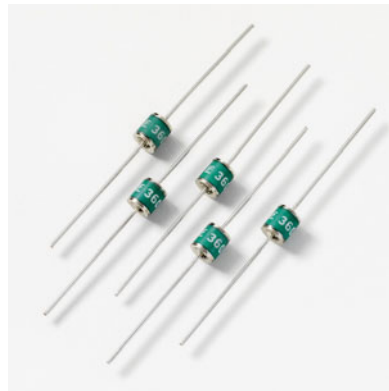

PRODUCT
CATALOG



GDT

Gas Discharge Tube
Products

DOWNLOAD
All Littelfuse Product Catalogs at
Littelfuse.com/catalogs

Littelfuse Circuit Protection Solutions Portfolio

Consumer Electronics | Telecom | White Goods | Medical Equipment | TVSS and Power Solutions

DESIGN SUPPORT

Live Application Design and Technical Support—Tap into our expertise. Littelfuse engineers are available around the world to help you address design challenges and develop unique, customized solutions for your products.

Product Sampling Programs—Most of our products are available as samples for testing and verification within your circuit design. Visit Littelfuse.com or contact a Littelfuse product representative for additional information.

Product Evaluation Labs and Services—Littelfuse global labs are the hub of our new product development initiatives, and also provide design and compliance support testing as an added-value to our customers.



OVERVOLTAGE SUPPRESSION TECHNOLOGIES (1-6)

1. TVS Diodes — Suppress overvoltage transients such as Electrical Fast Transients (EFT), inductive load switching and lightning in a wide variety of applications in the computer, industrial, telecom and automotive markets.

2. Varistors — Multiple forms, from Metal Oxide Varistors (MOVs) that suppress transient voltages to Multi-Layer Varistors (MLVs) designed for applications requiring protection from various transients in computers and handheld devices as well as industrial and automotive applications.

3. SIDACtor® Devices — Complete line of protection thyristor products specifically designed to suppress overvoltage transients in a broad range of telecom and datacom applications.

4. Gas Plasma Arrestors (GDTs) — Available in small footprint leaded and surface mount configurations, Littelfuse GDTs respond fast to transient overvoltage events, reducing the risk of equipment damage.

5. Silicon Protection Arrays — Designed specifically to protect analog and digital signal lines from electrostatic discharge (ESD) and other overvoltage transients.

6. PulseGuard® ESD Suppressors — Available in various surface mount form factors to protect high-speed digital lines without causing signal distortion.

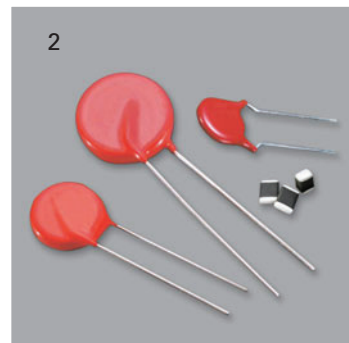
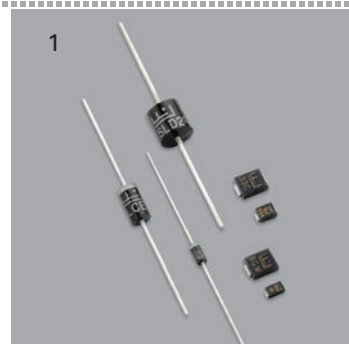

Visit

Protection folio

Supplies | Lighting | General Electronics

SWITCHING TECHNOLOGIES

Switching Thyristors— Solid-state switches used to control the flow of electrical current in applications, capable of withstanding rated blocking/off-state voltage until triggered to on-state.

SPECIAL APPLICATION PRODUCTS

PLED LED Lighting Reliability Devices— Specialty silicon devices that enable LED lighting strings to continue to function if any single LED fails as an open circuit, and also offer ESD and reverse power protection.

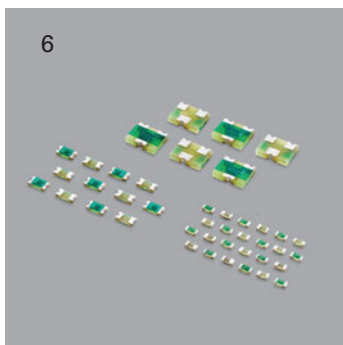
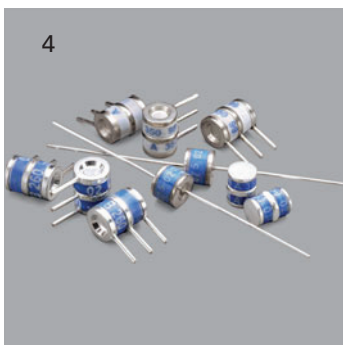
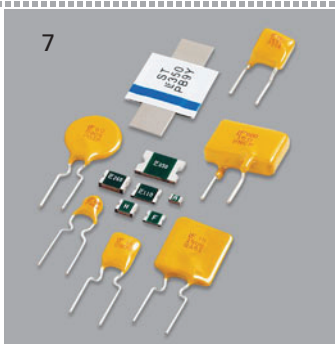
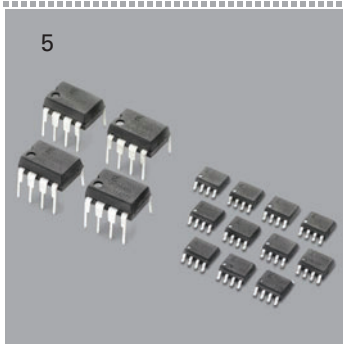
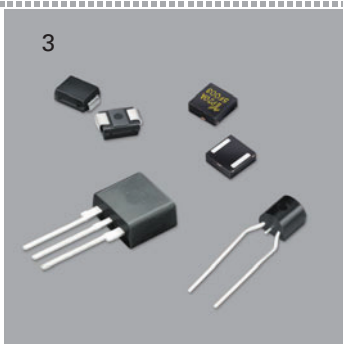
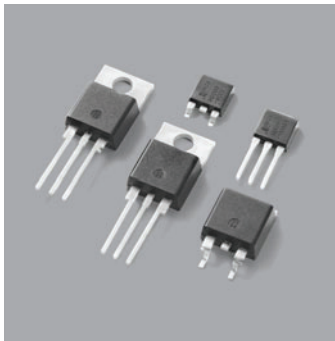

OVERCURRENT PROTECTION TECHNOLOGIES (7-8)

7. Positive Temperature Coefficient Devices (PTCs)— Provide resettable overcurrent protection for a wide range of applications.

8. Fuses— Full range including surface mount, axial, glass or ceramic, thin-film or Nano²® style, fast-acting or SloBlo[®], MINI[®] and ATO[®] fuses.

www.littelfuse.com for more information.

GDT (GAS DISCHARGE TUBE) PRODUCTS www.littelfuse.com/gdt

GDTs dissipate voltage transients through a contained plasma gas. They have high insulation resistance plus low capacitance and leakage to ensure minimal effect on normal operation of equipment. Littelfuse devices offer a small footprint and are available in leaded and surface mount configurations, with high surge handling capability. Their fast response to transient over-voltage events, and ability to dissipate large amounts of energy, translates into reduced risk of equipment damage. The amount of energy they can dissipate makes them a good choice for lightning surge protection, particularly for telecomm equipment located in outdoor structures.

Series Name ¹	DC Breakover Voltage Range (Nom V_{BO})	Max AC Surge Rating	Peak Pulse Current (8x20 μ s)	Max Capacitance	Operating Temperature Range	Mounting Options						Data Sheet Page	
						# Terminals	Mini Tube	Surface	Axial Lead	Radial Lead	Cartridge Clip		RoHS Compliant
High Voltage GDTs													
AC	 285 - 600	NA	5000A	1.5pF	-40°C to +90°C	2			•		•	3	
CG3	1000 - 7500		5000A	1.5pF		2			•		•	3	
Low to Medium Surge GDTs													
CG5	 90 - 600	5A	5000A	1.5pF	-40°C to +90°C	2	•	•	•		•	7	
SL0902A	90 - 600	5A	5000A	1.5pF		2	•	•			•	•	7
SL1002A	 75 - 600	5A	5000A	1.2pF		2	•	•			•	•	28
SL1003A	90 - 500	10A*	10,000A	1.2pF		3	•	•	•		•	•	33
SL1011A	75 - 600	5A	5000A	1.5pF		2	•	•			•	•	41
Medium to High Surge GDTs													
SL1122A	 90 - 260	10A*	10000A*	100-270pF	-40°C to +90°C	3			•		•	38	
SL1021A	90 - 600	10A*	10000A*	1.5pF		3	•	•			•	•	12
SL1024A	 90 - 600	10A*	10000A*	1.5pF		3	•	•			•	•	12
PMT8	90 - 400	10A*	20000A*	1.5pF		3	•	•			•	•	12
SL1011B	75 - 350	10A	10000A	1.5pF		2	•	•			•	•	41
SL1411A	75 - 600	10A	10000A	1.5pF		2	•	•			•	•	41
PMT3	 90 - 500	20A*	20000A*	1.5pF		3	•	•			•		17
CG/CG2	75 - 1000	20A	20000A	1.5pF		2	•	•	•		•		20
Very High Surge GDTs													
SL1021B	 90 - 600	10A*	20000A*	1.5pF	-40°C to +90°C	3	•	•			•	•	12
SL1024B	90 - 600	10A*	20000A*	1.5pF		3	•	•			•	•	12
SL1026	 275 - 700	10A*	20000A*			2				•	•	•	26

(1) Detailed information about most product series listed here can be found on our web site by entering [www.littelfuse.com/series/\(Series Name\).html](http://www.littelfuse.com/series/(Series Name).html)

* Total current through center (ground) terminal

RoHS  **AC and CG3 Series**

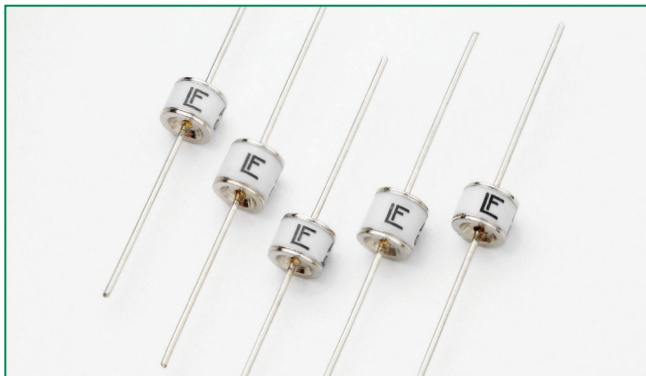

Agency Approvals

AGENCY	AGENCY FILE NUMBER
	E320116*

*NOTE: CG3 7.5 product UL approval is currently pending

2 Electrode GDT Graphical Symbol



Description

Littelfuse AC series two-electrode line protectors provide a high degree of surge protection in AC line applications. The two models, AC120 and AC240 are designed for use with 120VAC and 240VAC lines respectively. They are able to extinguish AC follow-on currents of at least 200A.

Littelfuse CG3 two electrode high voltage (1.0 - 7.5 KV) devices are designed for surge protection and high isolation applications, and for applications for which bias voltages or signal levels of several hundred volts are normally present.

Features

- Rugged ceramic-metal construction
- Available in tape-and-reel packaging
- Low capacitance (<1.5 pF)
- Available with or without leads

Applications

AC Series:

- Long branch circuits (AC wall outlet)
- Short branch circuits (at breaker box, computer, etc)
- Power supplies
- Test equipment
- Submersible pumps
- Medical electronics

CG3 Series:

- CRT terminals
- CATV equipment
- Antennas
- Power supplies
- Medical electronics

Electrical Characteristics

Part Number	Device Dimension Type	Device Specifications (at 25°C)							Life Ratings					
		DC Breakdown in Volts (@100V/s)			Impulse Break-down in Volts (@100V/μs)	Impulse Break-down In Volts (@1 Kv/μsec)	Insulation Resistance	Capacitance (@1MHz)	Arc Voltage (on state Voltage) @1Amp Min	Max Follow On Current ³	Nominal AC Discharge Current (10x1sec @50-60Hz)	AC Discharge Current (1 x 50Hz 9 cycles)	Nominal Impulse Discharge Current ⁴ (@8/20μs)	Max Surge Current ⁵ (@8/20μs)
		MIN	TYP	MAX	MAX		MIN	MAX	TYP					
AC120 ¹	A	230	285	340	500	550	10 GΩ (at 100V)	<1.5 pf	~ 25 V	200 Amps	5 A	65 A	10 shots 5kA	1 shot 10kA
AC240 ¹	A	480	600	720	1100	1200								
CG3 1.0 ¹	A	800	1000	1200	1400	1500	10 GΩ (at 100V)	<1.5 pf	~ 25 V	200 Amps	N/A	N/A	10 shots 5kA	1 shot 10kA
CG3 1.1 ¹	A	880	1100	1320	1600	1700								
CG3 1.2 ¹	A	960	1200	1440	1700	1800								
CG3 1.3 ¹	A	1040	1300	1560	1800	1900								
CG3 1.5 ¹	A	1200	1500	1800	1800	2000								
CG3 2.0 ¹	A	1600	2000	2400	2500	2750								
CG3 2.5 ¹	A	2000	2500	3000	3200	3500								
CG3 2.7 ¹	A	2160	2700	3240	3600	4000								
CG3 3.0 ¹	A	2400	3000	3600	4000	4200								
CG3 3.3 ¹	A	2640	3300	3960	4600	4700								
CG3 4.0 ²	B	3200	4000	4800	5800	6000								
CG3 4.5 ²	B	3600	4500	5400	6150	6500								
CG3 5.0 ²	B	4000	5000	6000	7500	8000								
CG3 6.2 ^{2,7}	B	4960	6200	7440	8100	9500								
CG3 6.5 ^{2,7}	B	5200	6500	7800	9500	10000								
CG3 7.5 ^{2,6,7}	B	6000	7500	9000	10000	10600								

NOTES:

1. Refer to Production Dimensions section, outline A devices
2. Refer to Production Dimensions section, outline B devices
3. Tested to UL1449 Third Edition – 120V r.m.s. for AC120, 230V r.m.s. all others.
Conducted with suitable MOV connected in series.
4. 10 x [5(+)] and 5(-)] applications 5kA @ 8/20μs
5. 1 x [1(+)] and 1(-)] application 10kA @ 8/20μs
6. CG3 75 product UL approval is currently pending
7. When ordering this item, use suffix code D004 when entering the part number.
The older product version without D004 suffix code has been discontinued.
Refer to Part Numbering System section for additional information.

Product Characteristics

Materials	Core Outline A & B items: Device: Tin Plated 17.5±12.5 Microns Axial Outline A items: Device: Nickel Plated 2–5 Microns Wire: Tin Plated 17.5±12.5 Microns Axial Outline B items: Device & Wire: Tin Plated 17.5±12.5 Microns
Product Marking	LF Logo, Voltage and date code; Black ink positive print
Glow to arc transition current	< 0.5Amps
Glow Voltage	~ 140 Volts
Storage and Operational Temperature	-40 to +90

Soldering Parameters - Reflow Soldering (Surface Mount Devices)

Reflow Condition		Pb – Free assembly
Pre Heat	- Temperature Min ($T_{s(min)}$)	150°C
	- Temperature Max ($T_{s(max)}$)	200°C
	- Time (Min to Max) (t_s)	60 – 180 secs
Average ramp up rate (Liquidus Temp (T_L) to peak)		3°C/second max
$T_{s(max)}$ to T_L - Ramp-up Rate		5°C/second max
Reflow	- Temperature (T_L) (Liquidus)	217°C
	- Temperature (t_L)	60 – 150 seconds
Peak Temperature (T_p)		260 ^{+0/-5} °C
Time within 5°C of actual peak Temperature (t_p)		10 – 30 seconds
Ramp-down Rate		6°C/second max
Time 25°C to peak Temperature (T_p)		8 minutes Max.
Do not exceed		260°C

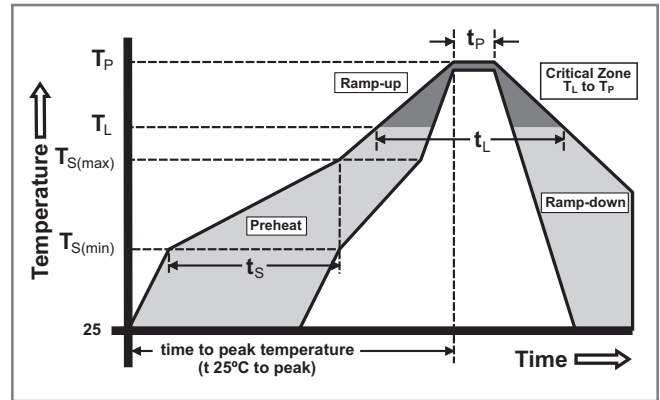

Soldering Parameters - Wave Soldering (Thru-Hole Devices)

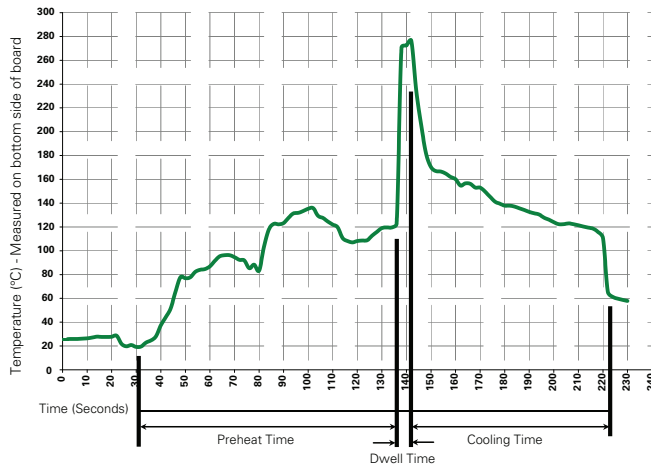

Recommended Process Parameters:

Wave Parameter	Lead-Free Recommendation
Preheat: (Depends on Flux Activation Temperature)	(Typical Industry Recommendation)
Temperature Minimum:	100° C
Temperature Maximum:	150° C
Preheat Time:	60-180 seconds
Solder Pot Temperature:	280° C Maximum
Solder Dwell Time:	2-5 seconds

Soldering Parameters - Hand Soldering

Solder Iron Temperature: 350° C +/- 5°C
 Heating Time: 5 seconds max.

Device Dimensions

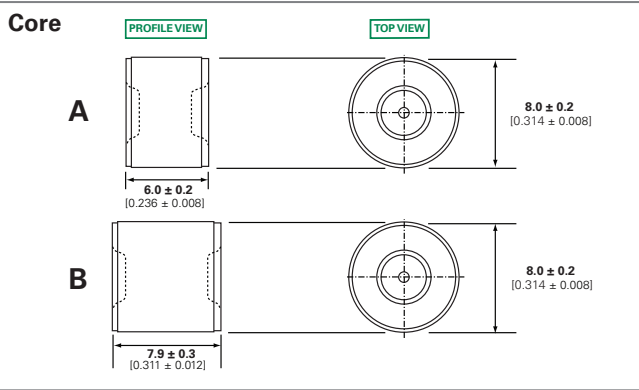
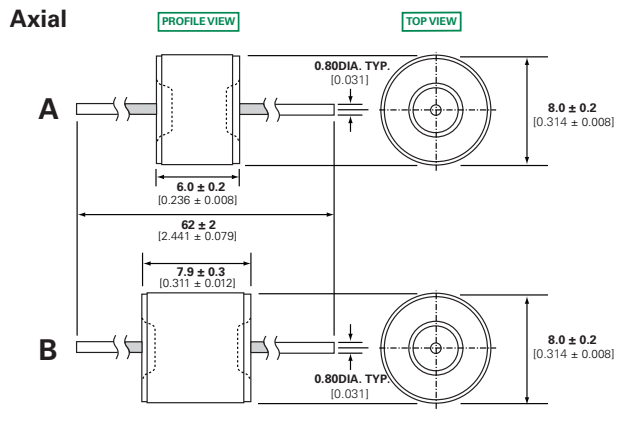

Packaging Dimensions

For 'LTR' Option Code Axial Lead Items

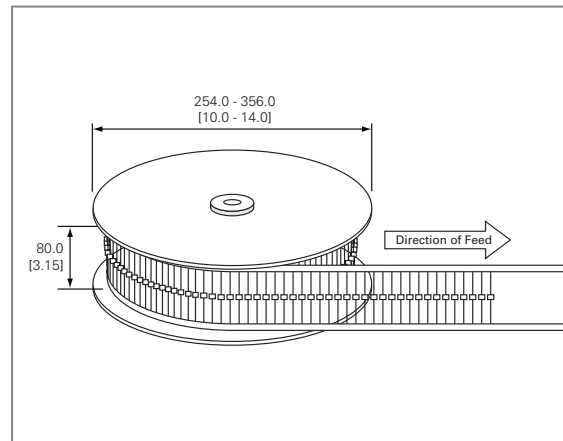
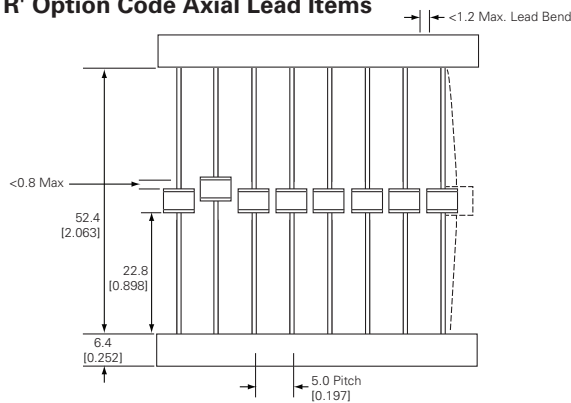

Part Numbering System and Ordering Information

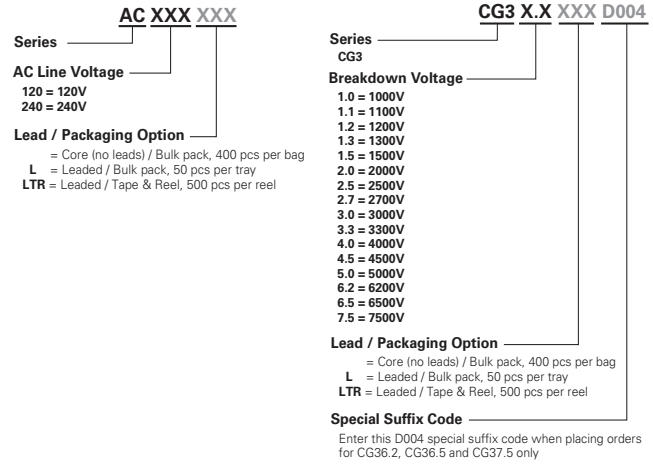

RoHS  **CG5 and SL0902A Series**

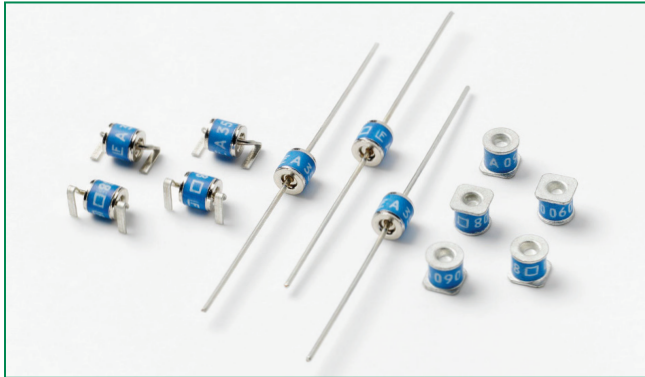

Description

Littelfuse Broadband Optimized™ SL0902A Series offers high surge ratings in a miniature package. Special design features provide high levels of protection against fast rising transients in the 100V/μs to 1kV/μs range usually caused by lightning disturbances. Low insertion loss is perfectly suited to broadband equipment applications. The capacitance does not vary with voltage, and will not cause operational problems with ADSL2+, where capacitance variation across Tip and Ring is undesirable. These devices are extremely robust and are able to divert a 2500A pulse without destruction. For AC Power Cross of long duration, overcurrent protection is recommended.

Littelfuse CG5 MS mini surge arresters are specifically designed for protection of electrical and communication equipment against over voltage transients in surface mount assembly applications. This series offers the most cutting edge protection using non-radioactive elements.

Agency Approvals

AGENCY	AGENCY FILE NUMBER
	E128662

2 Electrode GDT Graphical Symbol



Features

- RoHS compliant and Lead-free
- GHz working frequency
- Excellent stability on multiple pulse duty cycle
- Excellent response to fast rising transients.
- Ultra Low Insertion Loss
- 2.5KA surge capability tested with 8/20μS pulse as defined by IEC 61000-4-5
- Ultra small devices offered in a variety of mounting lead forms
- Non-Radioactive
- Low capacitance (<1pF)
- Voltage Ranges 90V to 600V
- UL recognized
- Conforms to ITU-T K12, IEC 1000-4-5

Applications

- Communication equipment
- CATV equipment
- Test equipment
- Data lines
- Power supplies
- Telecom SLIC protection
- Broadband equipment
- ADSL equipment, including ADSL2+
- XDSL equipment
- Satellite and CATV equipment
- General telecom equipment

Electrical Characteristics

Part Number	Device Specifications (at 25°C)						Life Ratings					
	DC Breakdown in Volts (@100V/s)			Impulse Breakdown in Volts (@100V/μs)	Impulse Breakdown In Volts (@1 Kv/μsec)	Insulation Resistance	Capacitance (@1MHz)	Surge Life (10/1000μs)	Nominal Impulse Discharge Current (8/20μs)	Nominal AC Discharge Current (10x1sec @50-60Hz)	AC Discharge Current (9 cycle @50Hz)	Max Impulse Discharge Current (1 Application @ 10/350μs)
	MIN	TYP	MAX	MAX		MIN	MAX					
SL0902A90 CG590	72	90	108	550	700	10 ¹⁰ Ω (at 50V)		300 shots (@100A)	10 shots (@5kA) ⁵	5 A	10 A	0.5kA
CG5145	116	145	174	550	650	10 ¹⁰ Ω (at 100V)	1.5 pf	300 shots (@100A)	10 shots (@5kA) ⁵	5 A	10 A	0.5kA
CG5150	120	150	180	550								
SL0902A230 CG5230	184	230	276	550	650							
CG5250	200	250	300	600								
CG5270	216	270	324	650								
SL0902A350 CG5350	280	350	420	800	900							
CG5400	320	400	480	900								
SL0902A420	336	420	504	900	1000							
CG5550	440	550	660	1350								
SL0902A600 CG5600	480	600	720	1350	1500							

Product Characteristics

Materials	CG5xxxLS (Outline 500), CG5xxxxLTR & CG5350L-03TR (Outline 502), and CG5xxxL-02 (Outline 503): Device Nickel Plated 2–5 Microns Wire Tin Plated 17.5±12.5 Microns Construction Ceramic Insulator.
	CG5xxx (Outline 501), and CG5xxxMS & SL0902AxxxSM (Outline 505): Device Tin Plated 17.5±12.5 Microns Construction Ceramic Insulator.

Product Marking	LF Logo, Voltage and date code
Glow to arc transition current	< 0.5Amps
Glow Voltage	140 Volts
Storage and Operational Temperature	-40 to +90

Voltage vs. Time Characteristic

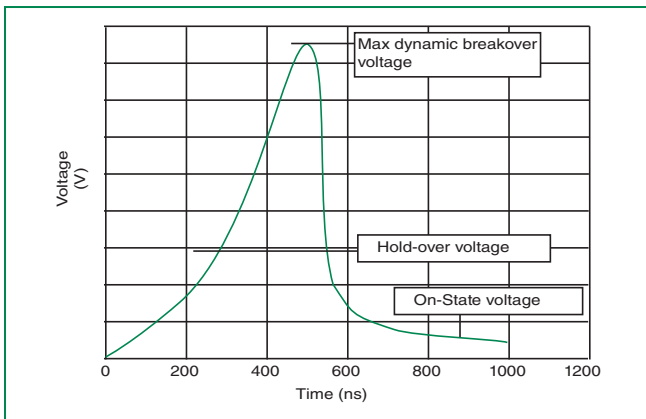

Typical Insertion Loss

@ 1.0 GHz = 0.01 dB
@ 1.4GHz = 0.1 dB
@ 1.8 GHz = 0.53 dB
@ 2.1 GHz = 0.81 dB
@ 2.45 GHz = 1 dB
@ 2.8 GHz = 1.2 dB
@ 3.1 GHz = 1.5 dB
@ 3.5 GHz = 2.1 dB

Device Dimensions

Outline 500 - CG5xxxLS

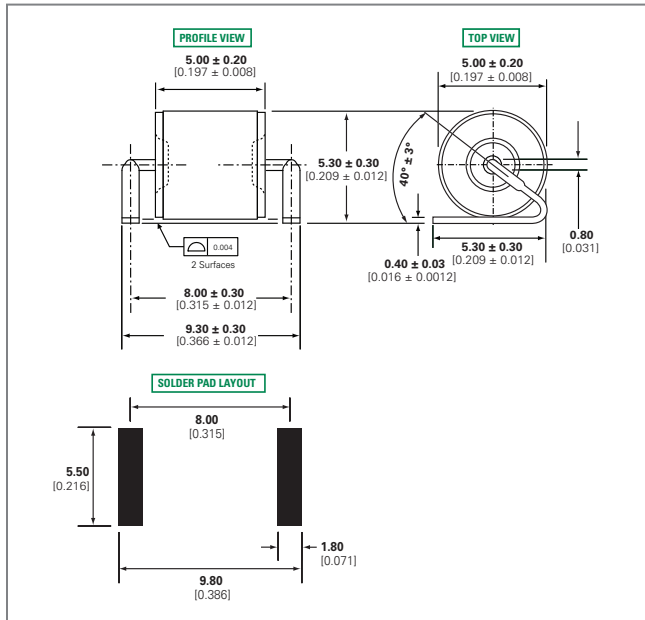

Outline 503 - CG5xxxL-02 (except CG5600L-02, see Outline 502)

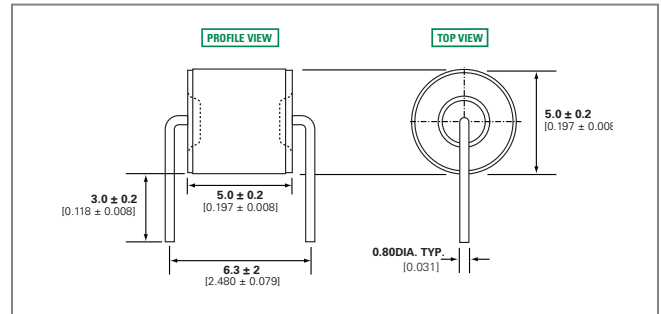

Outline 505 - CG5xxxMS and SL0902AxxxSM

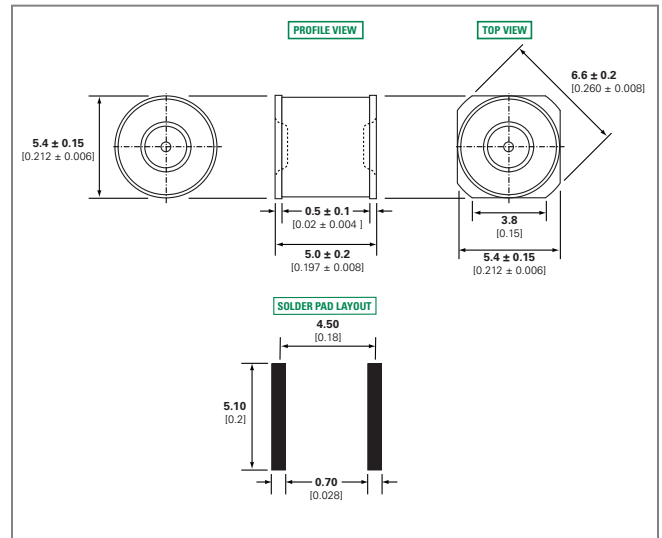

Outline 501 - CG5xxx

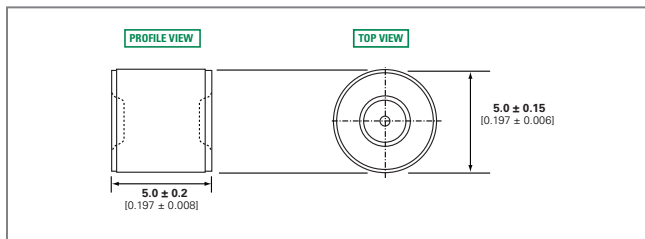

Outline 502 - CG5xxxLTR (also CG5350L-03TR, CG5600L-02)

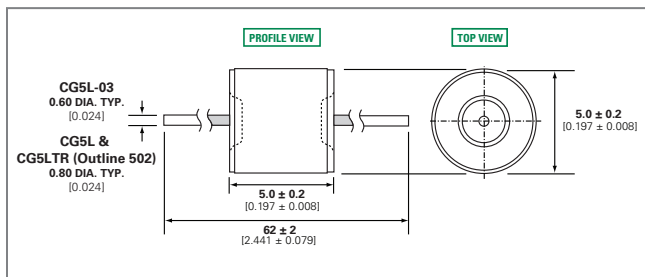

Soldering Parameters - Reflow Soldering (Surface Mount Devices)

Reflow Condition		Pb – Free assembly
Pre Heat	- Temperature Min ($T_{s(min)}$)	150°C
	- Temperature Max ($T_{s(max)}$)	200°C
	- Time (Min to Max) (t_s)	60 – 180 secs
Average ramp up rate (Liquidus Temp (T_L) to peak)		3°C/second max
$T_{s(max)}$ to T_L - Ramp-up Rate		5°C/second max
Reflow	- Temperature (T_L) (Liquidus)	217°C
	- Temperature (t_L)	60 – 150 seconds
Peak Temperature (T_p)		260 ^{+0/-5} °C
Time within 5°C of actual peak Temperature (t_p)		10 – 30 seconds
Ramp-down Rate		6°C/second max
Time 25°C to peak Temperature (T_p)		8 minutes Max.
Do not exceed		260°C

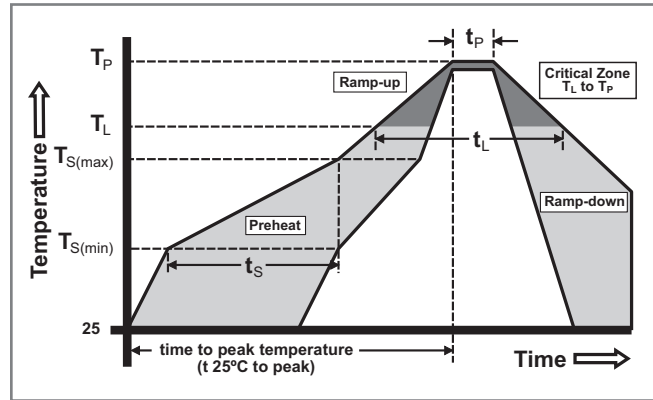

Soldering Parameters - Hand Soldering

Solder Iron Temperature: 350° C +/- 5°C
 Heating Time: 5 seconds max.

Soldering Parameters - Wave Soldering (Thru-Hole Devices)

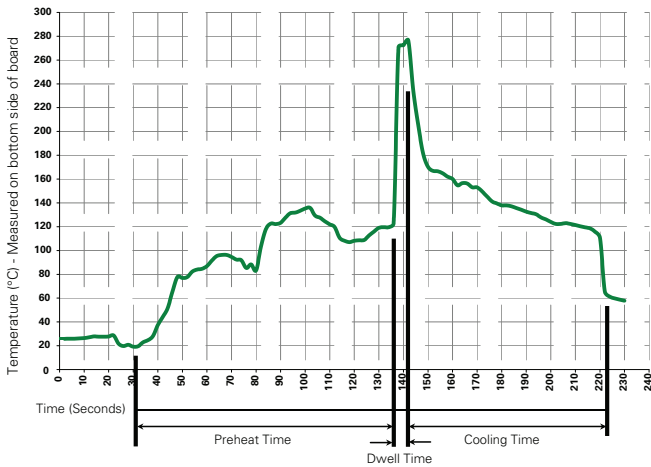

Recommended Process Parameters:

Wave Parameter	Lead-Free Recommendation
Preheat: (Depends on Flux Activation Temperature)	(Typical Industry Recommendation)
Temperature Minimum:	100° C
Temperature Maximum:	150° C
Preheat Time:	60-180 seconds
Solder Pot Temperature:	280° C Maximum
Solder Dwell Time:	2-5 seconds

Note: These devices are not recommended for IR or Convection Reflow process.

Part Numbering System and Ordering Information

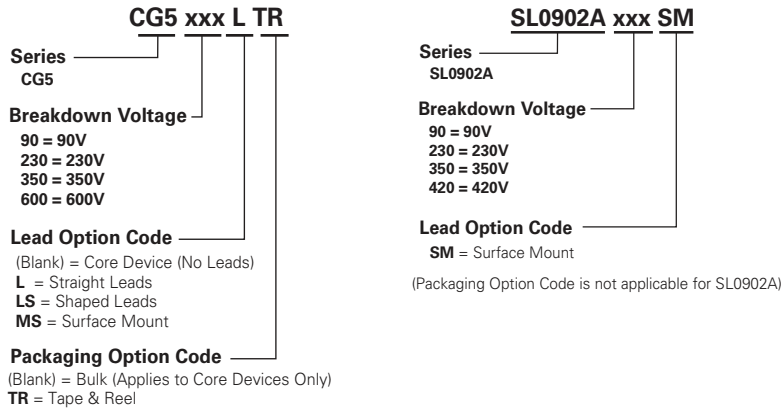

Packaging

Part Number and Device Type		Device Dimensions Reference	Quantity and Packaging Description
CG5xxx	Core	Outline 501	1000pcs/bag in bulk packaging
CG5xxxLS	Shaped Leads	Outline 500	900pcs/reel in carrier and tape*
CG5xxxLTR CG5xxxL-03TR**	Straight Axial Leads	Outline 502	1000pcs/reel in tape and reel*
CG5xxxL-02**	Bent Radial Leads	Outline 503	50pcs/tray in tray and cover
CG5xxxMS SL0902AxxxSM	Surface mount	Outline 505	900pcs/reel in carrier and tape*

* For tape specifications and dimensions, please contact factory.
 ** Special order items not available for general sale. Please contact Littelfuse for details.

RoHS  **SL1021A/B, SL1024A/B and PMT8 Series**



Description

GDT circuit protection devices dissipate electrical surge energy safely within a contained plasma gas. Commonly used to help protect sensitive telecom and networking equipment and lines, GDTs protect from damage that may result from lightning strikes and equipment switching operations.

The Littelfuse GDT series described in this document are available in a variety of leaded and surface mount forms and offered with and without optional fail-safe clip. Please refer to the electrical specifications, dimension and packaging options section of this document for additional information.

SL1021A/B and SL1024A/B Series:

SL1021A/B and SL1024A/B series GDTs are designed to offer high levels of performance on fast rising transients in the range of 100V/μS to 1KV/μS, which are those most likely created by induced lightning disturbances.

These devices feature ultra low capacitance (typically 1.5pF or less) and are extremely robust with SL102xA devices able to divert a 10,000 Amp pulse without destruction, and SL102xB suffix devices able to divert a 20,000 Amp pulse without destruction.

These series offer optimized internal geometry which provide low insertion loss at high frequencies, ideal for the protection of broadband and other high speed transmission equipment.

PMT8 Series:

PMT8 GDT's are telecom grade devices designed to meet the recommendations in CCITT-K12 and Bellcore GR-1361-CORE. The three electrode configuration is used in applications where simultaneous crowbar action of two signal lines is required.

Agency Approvals

AGENCY	AGENCY FILE NUMBER
	E128662

3 Electrode GDT Graphical Symbol

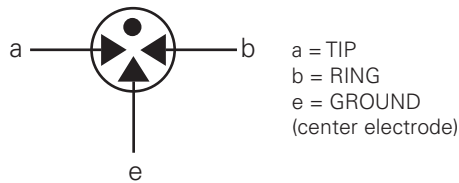

Features

- RoHS compliant
- Low insertion loss
- Excellent response to fast rising transients
- Ultra low capacitance
- 10KA (A suffix devices) / 20KA (B suffix devices) surge capability tested with 8/20μs pulse as defined by IEC 61000-4-5
- Available with thermal failsafe option (add 'F' suffix to part number)

Applications

SL1021 / SL1024:

- Broadband equipment
- ADSL equipment
- XDSL equipment
- Satellite and CATV equipment
- Splitters
- General telecom equipment

PMT8:

- Telecom network interfaces
- Telephone line cards
- Repeaters
- Modems
- Line test equipment

Product Characteristics

Materials	Dull Tin Plate 17.5 ± 12.5 Microns. with ceramic insulator
Product Marking	'LF' mark, voltage & date code: SL102xA - Red/White text SL102xB & PMT8 - Blue/White text
Glow to arc transition current	~ 1Amp
Glow Voltage	~60-200 Volts
Storage and Operation Temperature	-40 to +90°C
Transverse Voltage (Delay Time)	< 0.2μSec (Tested to ITU-T Rec. K.12)
Arc Voltage	~10 to 35 Volts
Holdover Voltage	<150mS (Tested to ITU-T Rec. K.12)

Electrical Characteristics

Device Specifications (at 25°C)							Life Ratings					
Part Number*	DC Voltage 100V/Sec.			DC Voltage 100 V/μSec.	DC Voltage 1kV/μSec.	Capacitance (@1Mhz)	Insulation Resistance	AC Current 50Hz 1Sec.x10 ¹	Surge Current 8/20μSec x10 ¹	Max Single Surge 8/20μSec ¹	Max Single Surge 10/350μSec ¹	Surge Life 10/1000 μSecx300 ¹
	MIN	TYP	MAX									
SL1021A090 SL1024A090 SL1021B090 SL1024B090 PMT 8 090	72	90	108	500	650	<1.5pF	>10 ¹⁰ Ω (at 50V)	10Amps	10kA ² 20kA ³	15kA ² 25kA ³	4kA ² 5kA ³	200Amps
SL1021A145 SL1024A145 SL1021B145 SL1024B145	116	145	174		600						2.5kA ² 5kA ³	
SL1021A150 SL1024A150 SL1021B150 SL1024B150	120	150	180		650							
SL1021A200	150	200	250		700							
SL1021A230 SL1024A230 SL1021B230 SL1024B230 PMT 8 230	184	230	276	450	850	>10 ¹⁰ Ω (at 100V)	10Amps	10kA ² 20kA ³	15kA ² 25kA ³	2.5kA ² 5kA ³	200Amps	
SL1021A250 SL1024A250 SL1021B250 SL1024B250 PMT 8 250	200	250	300	500	900							
SL1021A260 SL1024A260 SL1021B260 SL1024B260	210	260	310	550	950							
SL1021A300 SL1024A300 SL1021B300 SL1024B300	240	300	360	650	1000							
SL1021A350 SL1024A350 SL1021B350 SL1024B350 PMT 8 350	280	350	420	700	1100							
SL1021A400 SL1024A400 SL1021B400 SL1024B400 PMT 8 400	320	400	480	850	1200							
SL1021A420 SL1024A420 SL1021B420 SL1024B420	345	420	500									
SL1021A450 SL1024A450 SL1021B450 SL1024B450	360	450	540	900								
SL1021A500 SL1024A500 SL1021B500 SL1024B500	400	500	600	950								
SL1021A600 SL1024A600	480	600	720	1000								

NOTES:

*Max capacitance is 1.5 pF, measured at 1 MHz.

1. Total current through centre electrode, tested in accordance with ITU-T Rec K.12
2. SL A series
3. SL B series & PMT 8 series

Time vs. Current for Failsafe

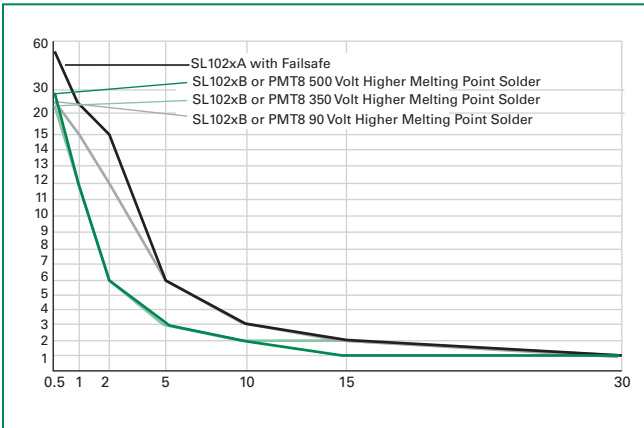

Voltage vs. Time Characteristic

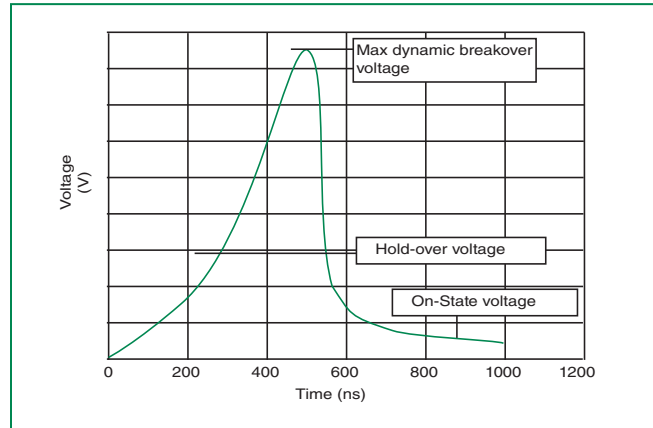

Soldering Parameters - Reflow Soldering (Surface Mount Devices)

Reflow Condition		Pb – Free assembly
Pre Heat	- Temperature Min ($T_{s(min)}$)	150°C
	- Temperature Max ($T_{s(max)}$)	200°C
	- Time (Min to Max) (t_s)	60 – 180 secs
Average ramp up rate (Liquidus Temp (T_L) to peak)		3°C/second max
$T_{s(max)}$ to T_L - Ramp-up Rate		5°C/second max
Reflow	- Temperature (T_L) (Liquidus)	217°C
	- Temperature (t_L)	60 – 150 seconds
Peak Temperature (T_p)		260 ^{+0/-5} °C
Time within 5°C of actual peak Temperature (t_p)		10 – 30 seconds
Ramp-down Rate		6°C/second max
Time 25°C to peak Temperature (T_p)		8 minutes Max.
Do not exceed		260°C

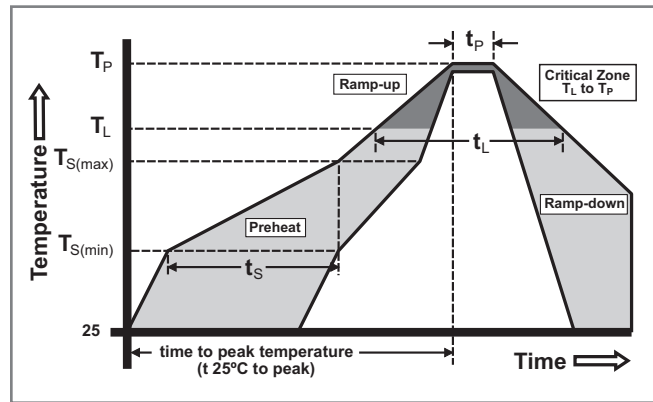

Soldering Parameters - Hand Soldering

Solder Iron Temperature: 350° C +/- 5°C
Heating Time: 5 seconds max.

Soldering Parameters - Wave Soldering (Thru-Hole Devices)

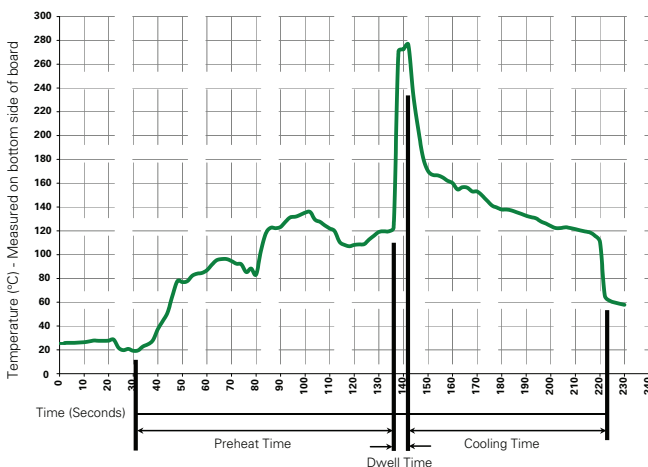

Recommended Process Parameters:

Wave Parameter	Lead-Free Recommendation
Preheat: (Depends on Flux Activation Temperature) (Typical Industry Recommendation)	
Temperature Minimum:	100° C
Temperature Maximum:	150° C
Preheat Time:	60-180 seconds
Solder Pot Temperature:	280° C Maximum
Solder Dwell Time:	2-5 seconds

Note: Surge Arrestors with a Failsafe mechanism should be individually examined after soldering

Device Dimensions

NOTE: Failsafe option dimensions shown in green.

Shaped Radial Ledged Devices:

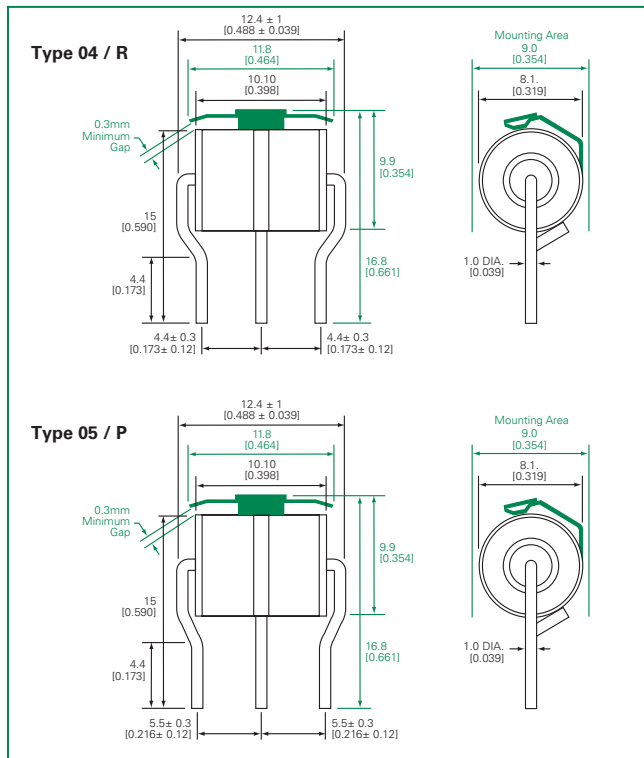

Surface Mount Devices:

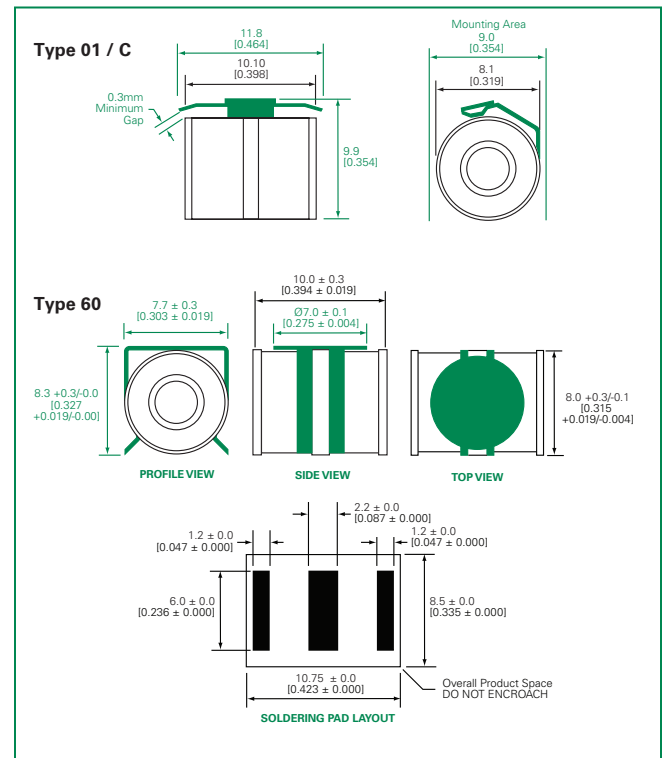

Straight "T" Ledged Devices:

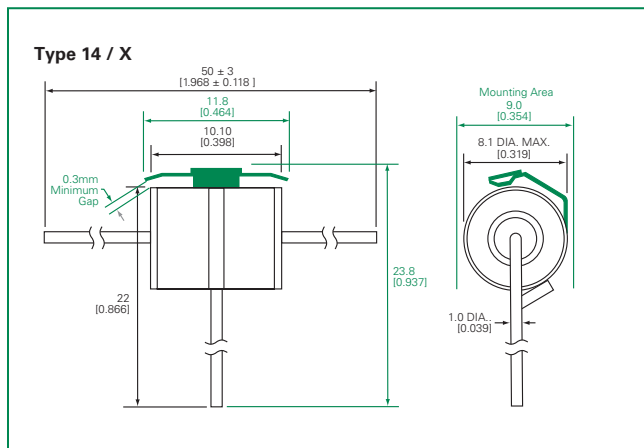

Straight Radial Ledged Devices:

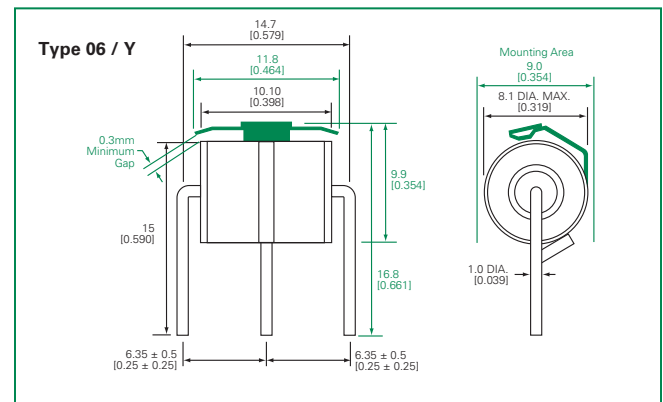

Part Numbering System and Ordering Information

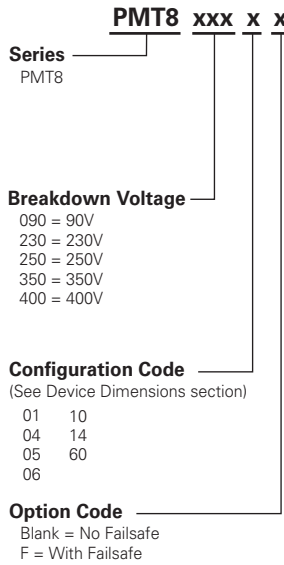
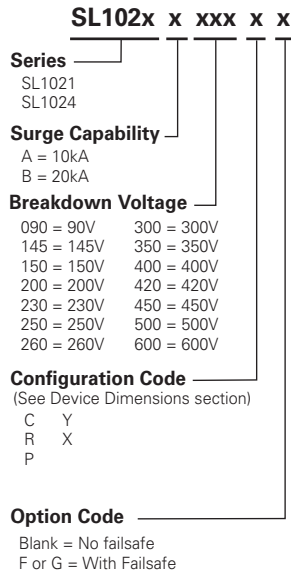

Packaging

Device Type	Description	Quantity
Type 01 / C	100pcs/tray x 5 trays per carton	500
Type 04 / R	100pcs/tray x 5 trays per carton	500
Type 05 / P	100pcs/tray x 5 trays per carton	500
Type 06 / Y	100pcs/tray x 5 trays per carton	500
Type 14 / X	50pcs/tray x 5 trays per carton	250
Type 60	500pcs/reel* x 10 reels per carton	5000

* For tape and reel specifications, please contact factory.

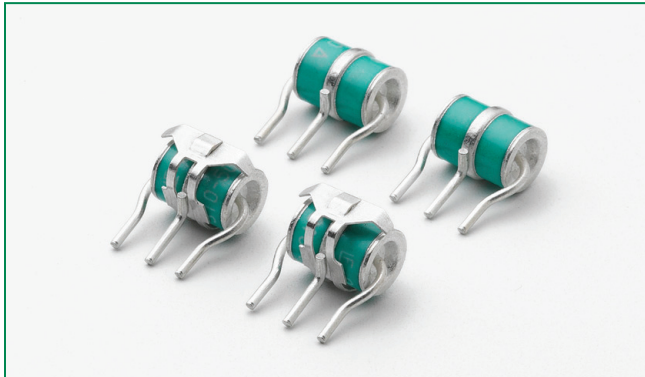
RoHS  PMT3(310) Series

Agency Approvals

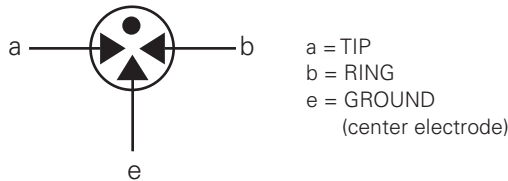
AGENCY	AGENCY FILE NUMBER
	E128662

3 Electrode GDT Graphical Symbol

Description

Littelfuse three electrode PMT3(310) series GDTs are designed primarily to protect telecommunications equipment requiring simultaneous crowbar action of two signal lines. GDTs function as switches; dissipating a minimum amount of energy and can handle much higher currents than other types of transient voltage protection.

Features

- Rugged ceramic-metal construction
- Low capacitance (<1.5 pF)
- Available with or without fail-safe clip
- Available with or without leads
- Available with various lead spacings
- Tested to REA PE-80

Applications

- Telephone interface
- Telephone line cards
- Repeaters
- Modems
- Line test equipment

Electrical Characteristics

Part Number	Device Specifications						Life Ratings						
	DC Breakdown (I-g) @500V/μs			DC Voltage 100 V/μSec.	DC Voltage 1kV/μSec.	Insulation Resistance Min	Capacitance (@1Mhz)	AC Current 11 cycles @ 50-60Hz ¹	AC Current 50Hz 1Sec. x10 ¹	Surge Current 8/20μSec x10 ¹	Max Single Surge 8/20 μSec ¹	Max Single Surge 10/350 μSec ¹	Surge Life 10/1000 μSec x 400 ¹
	Min	Typ	Max										
PMT3(310)075	60	75	90	500	650	10 ¹⁰ Ω (at 50V) 10 ¹⁰ Ω (at 100V)	1.5 pf	130Amps	20Amps	20kA	25kA	5kA	1kA
PMT3(310)090	72	90	108	500	650								
PMT3(310)150	120	150	180	500	600								
PMT3(310)230	184	230	276	600	700								
PMT3(310)250	200	250	300	600	700								
PMT3(310)350	280	350	420	900	1000								
PMT3(310)400	320	400	480	900	1000								
PMT3(310)500	400	500	600	1100	1200								

NOTES:

- Total current through center electrode, tested in accordance with ITU-T Rec K.12 and REA PE 80
- End of life DC: 50% of minimum initial DC breakdown voltage to 150% of maximum initial DC breakdown voltage limit.
- Impulse: less than 150% of initial impulse breakdown down limit.

Product Characteristics

Materials	Dull Tin Plate 17.5 ± 12.5 Microns with Ceramic Insulator
Product Marking	Littelfuse 'LF' marking, Voltage and date code.
Glow to arc transition current	~ 1Amp
Glow Voltage	~ 60-200 Volts

Storage and Operational Temperature	-40 to +90°C
Transverse Voltage (Delay Time) Tested to ITU-T Rec. K.12	< 0.2µSec
Arc Voltage	~ 10 to 35 Volts
Holdover Voltage Tested to ITU-T Rec. K.12 & REA PE 80	< 150mS

Soldering Parameters - Reflow Soldering (Surface Mount Devices)

Reflow Condition		Pb – Free assembly
Pre Heat	- Temperature Min ($T_{s(min)}$)	150°C
	- Temperature Max ($T_{s(max)}$)	200°C
	- Time (Min to Max) (t_s)	60 – 180 secs
Average ramp up rate (Liquidus Temp (T_L) to peak)		3°C/second max
$T_{s(max)}$ to T_L - Ramp-up Rate		5°C/second max
Reflow	- Temperature (T_L) (Liquidus)	217°C
	- Temperature (t_L)	60 – 150 seconds
Peak Temperature (T_p)		260 ^{+0/-5} °C
Time within 5°C of actual peak Temperature (t_p)		10 – 30 seconds
Ramp-down Rate		6°C/second max
Time 25°C to peak Temperature (T_p)		8 minutes Max.
Do not exceed		260°C

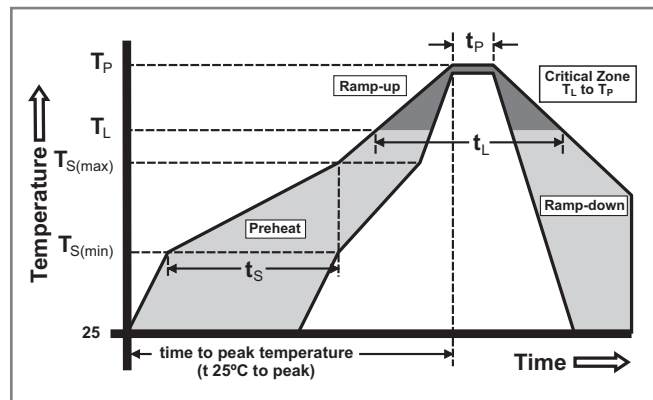

Soldering Parameters - Hand Soldering

Solder Iron Temperature: 350° C +/- 5°C
 Heating Time: 5 seconds max.

Soldering Parameters - Wave Soldering (Thru-Hole Devices)

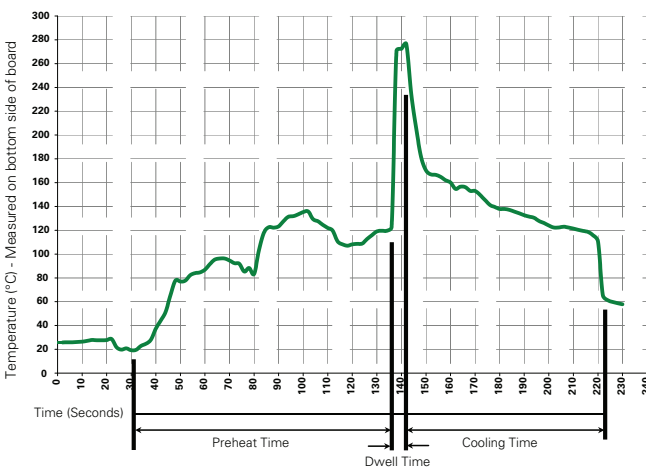

Recommended Process Parameters:

Wave Parameter	Lead-Free Recommendation
Preheat: (Depends on Flux Activation Temperature) (Typical Industry Recommendation)	
Temperature Minimum:	100° C
Temperature Maximum:	150° C
Preheat Time:	60-180 seconds
Solder Pot Temperature:	280° C Maximum
Solder Dwell Time:	2-5 seconds

Note: Surge Arrestors with a Failsafe mechanism should be individually examined after soldering

Device Dimensions

NOTE: Failsafe option dimensions shown in green.

Type 01 - Surface Mount Core

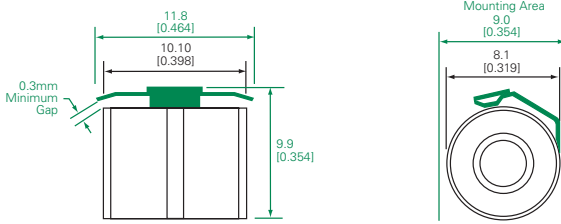

Type 04 - Shaped Radial Leads

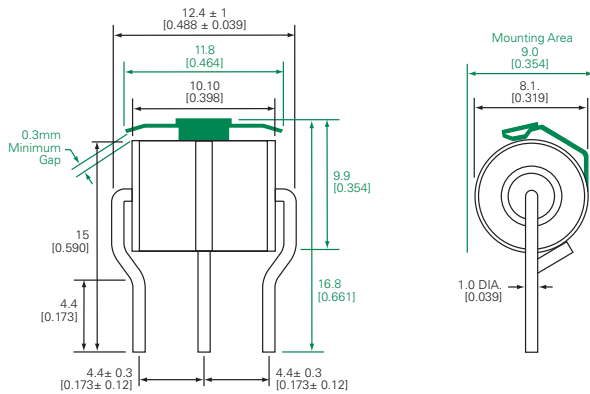

Type 06 - Straight Radial Leads

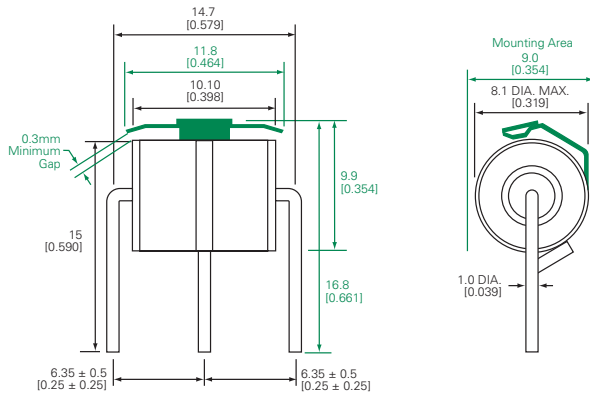

Type 14 - Straight "T" Leads

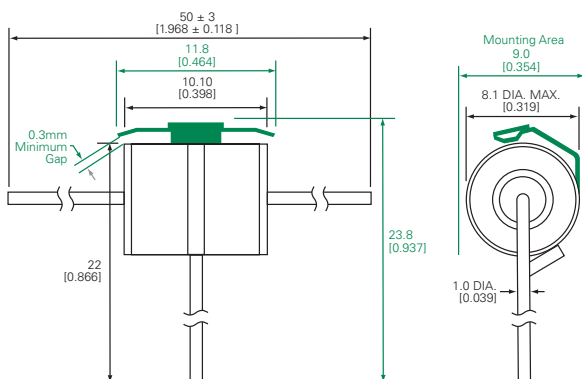

Packaging

Device Type	Description	Quantity
Type 01	100pcs/tray x 5 trays per carton	500
Type 04	100pcs/tray x 5 trays per carton	500
Type 06	100pcs/tray x 5 trays per carton	500
Type 14	50pcs/tray x 5 trays per carton	250

Part Number	Available Package Option			
	Type 01	Type 04	Type 06	Type 14
PMT3(310)075		X		
PMT3(310)090		X		
PMT3(310)150	X	X	X	X
PMT3(310)230		X	X	
PMT3(310)250	X	X	X	X
PMT3(310)350		X	X	
PMT3(310)400		X	X	
PMT3(310)500		X	X	

Part Numbering System

PMT3(310) XXX XX X

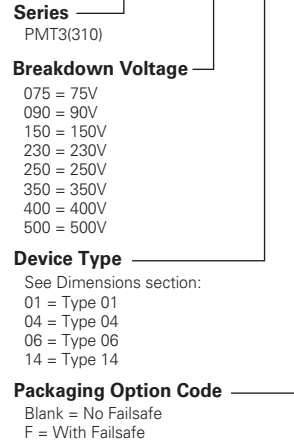

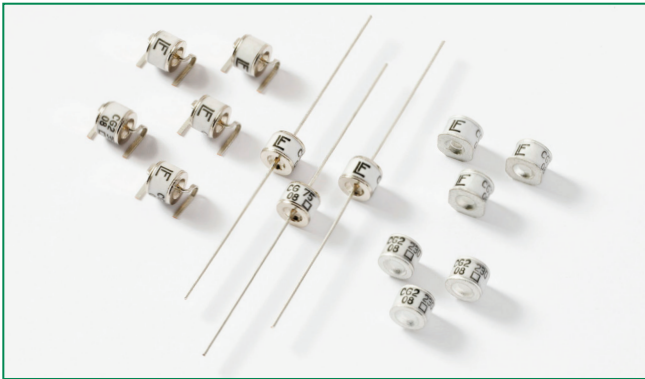

Description

Littelfuse highly reliable CG/CG2 Series GDTs provide a high degree of surge protection in a small size ideal for board level circuit protection.



GDTs function as switches which dissipate a minimum amount of energy and therefore handle currents that far surpass other types of transient voltage protection. Their gas-filled, rugged ceramic metal construction make them well suited to adverse environments.

The CG/CG2 series comes in a variety of forms including surface mount, core, straight and shaped leads, to serve a variety of mounting methods.

The CG Series (75-110V) is ideal for protection of test and communication equipment and other devices in which low voltage limits and extremely low arc voltages are required.

The CG2 Series (145V-1000V) is ideal for protecting equipment where higher voltage limits and holdover voltages are necessary.

Agency Approvals

AGENCY	AGENCY FILE NUMBER
	E128662
	E320116

2 Electrode GDT Graphical Symbol



Features

- Rugged Ceramic-Metal construction
- Low Capacitance (<1.5pf)
- Meets REA PE-80
- Available in surface mount, and a variety of lead options options

Applications

- Communication lines and equipment
- CATV equipment
- Test equipment
- Data lines
- Power supplies
- Instrumentation circuits
- Medical electronics
- ADSL equipment
- Telecom SLIC protection

Electrical Characteristics

Part Number	Device Specifications (at 25°C)						Life Ratings							
	DC Breakdown in Volts (@100V/s)			Impulse Break-down in Volts (@100V/μs)	Impulse Break-down In Volts (@1 Kv/μsec)	Insulation Resistance	Capacitance (@1MHz)	Arc Voltage (on state Voltage) @1Amp Min	Surge Life (@500A 10/1000μs)	Nominal Impulse Discharge Current (8/20μs)	Nominal AC Discharge Current (10x1 sec @50-60Hz)	AC Discharge Current (9 cycle @50Hz)	DC Holdover Voltage ²	Max Impulse Discharge Current (1 Application @ 10/350μs)
	MIN	TYP	MAX	MAX		MIN	MAX	TYP					TYP	
CG75	60	75	90	400	650	10 ¹⁰ Ω (at 50V)							52 V	4kA
CG90	72	90	108	400	600									
CG90 SN	72	90	108	400	600									
CG110	88	110	132	450	600	10 ¹⁰ Ω (at 100V)	1.5 pf	15 V	400 shots	10 shots (@20kA) ³	20 A	100 A	135 V	2.5kA
CG2145	116	145	174	500	600									
CG2145 SN	120	145	174	500	600									
CG2230	195	230	265	600	700									
CG2230 SN	184	230	276	600	700									
CG2250	213	250	288	625	725									
CG2250 SN	200	250	300	625	725									
CG2300	255	300	345	700	800									
CG2300 SN	240	300	360	700	800									
CG2350	297	350	403	750	900									
CG2350 SN	280	350	420	750	900									
CG2420	357	420	483	800	1000									
CG2470	400	470	540	850	1200									
CG2470 SN	376	470	564	850	1200									
CG2600	510	600	690	1000	1400									
CG2600 SN	480	600	720	1000	1400									
CG2800 ¹	680	800	920	1200	1500									
CG21000 ¹	850	1000	1150	1500	1600									

NOTES:

1. Tested to UL1449 Third Edition
2. Reference REA PE-80, 0.2A. Tested to ITU-T Rec K.12 and REA PE 80 < 150 mSec.
3. Leaded devices = 5x(5+) or 5 (-) applications 20kA 8/20μSec. (75 to 600 volt devices.)
MS and Core devices = 10x(5+) and 5(-) applications 10kA 8/20μS (800 to 1000 volt devices.)

Product Characteristics

Materials	LS, Axial: Device: Nickel Plated 2–5 Microns Lead Wires: Tin Plated 17.5 ± 12.5 Microns Construction: Ceramic Insulator Core: Device: Tin Plated 17.5 ± 12.5 Microns. Construction: Ceramic Insulator MS: Device: Dull Tin Plated 7–9 Microns Construction: Ceramic Insulator
	Product Marking

Glow to arc transition current	< 0.5Amps
Glow Voltage	60-160 Volts
Storage and Operational Temperature	-40 to +90
Maximum Follow On Current¹	230 Volts r.m.s, 200 Amps. (800V and 1000V devices tested to UL1449 3rd edition)

Device Dimensions

Leaded 'L' Type Straight Axial Devices

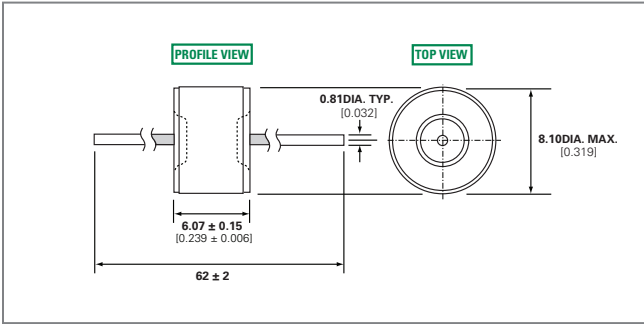

Leaded 'LS' Type Shaped Lead Devices

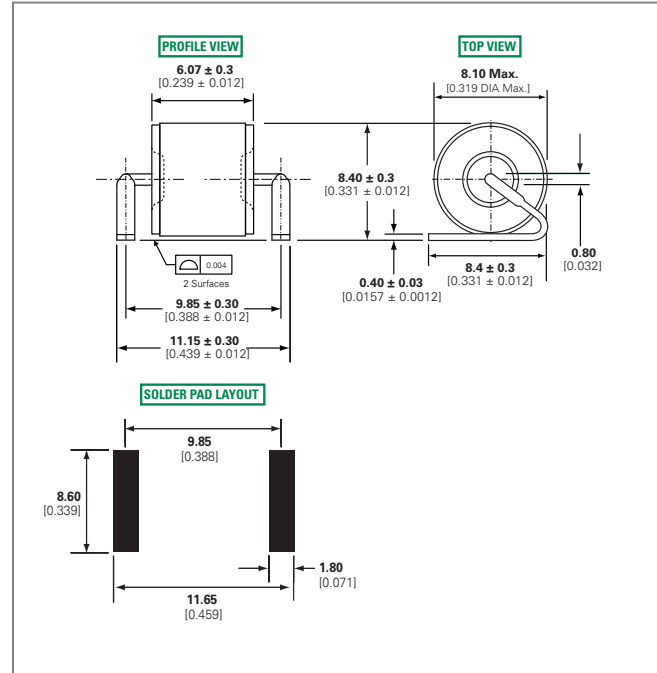

Core Devices

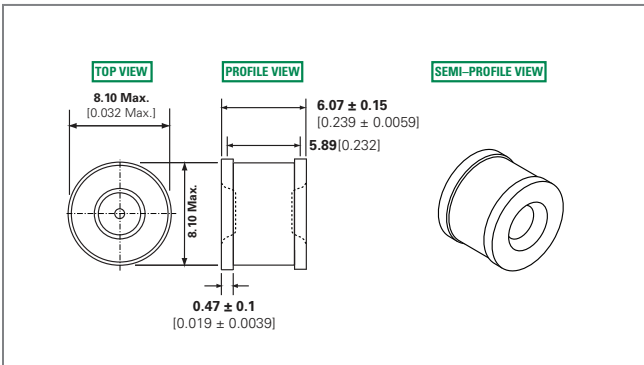

'MS' Type Devices

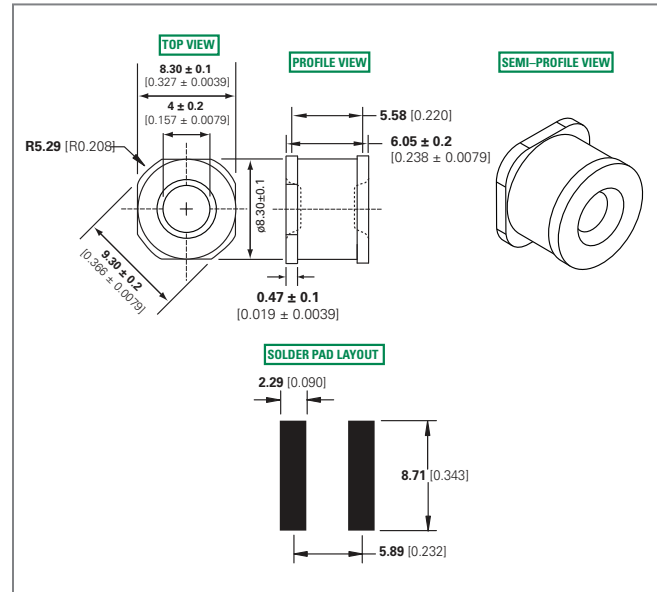

Soldering Parameters - Reflow Soldering (Surface Mount Devices)

Reflow Condition		Pb – Free assembly
Pre Heat	- Temperature Min ($T_{s(min)}$)	150°C
	- Temperature Max ($T_{s(max)}$)	200°C
	- Time (Min to Max) (t_s)	60 – 180 secs
Average ramp up rate (Liquidus Temp (T_L) to peak)		3°C/second max
$T_{s(max)}$ to T_L - Ramp-up Rate		5°C/second max
Reflow	- Temperature (T_L) (Liquidus)	217°C
	- Temperature (t_L)	60 – 150 seconds
Peak Temperature (T_p)		260 ^{+0/-5} °C
Time within 5°C of actual peak Temperature (t_p)		10 – 30 seconds
Ramp-down Rate		6°C/second max
Time 25°C to peak Temperature (T_p)		8 minutes Max.
Do not exceed		260°C

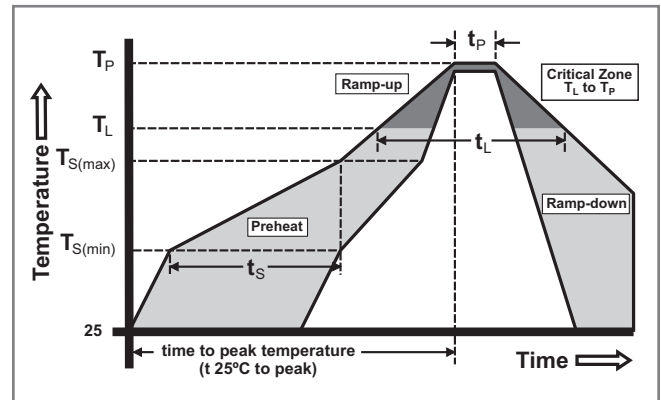

Soldering Parameters - Wave Soldering (Thru-Hole Devices)

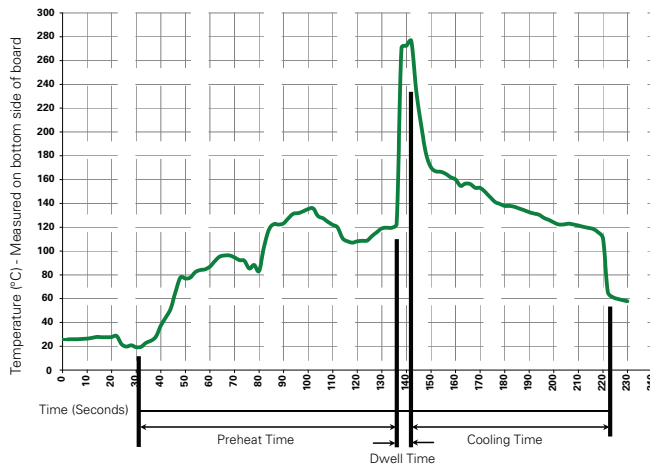

Recommended Process Parameters:

Wave Parameter	Lead-Free Recommendation
Preheat: (Depends on Flux Activation Temperature) (Typical Industry Recommendation)	
Temperature Minimum:	100° C
Temperature Maximum:	150° C
Preheat Time:	60-180 seconds
Solder Pot Temperature:	280° C Maximum
Solder Dwell Time:	2-5 seconds

Soldering Parameters - Hand Soldering

Solder Iron Temperature: 350° C +/- 5°C
 Heating Time: 5 seconds max.

Packaging Dimensions

For 'L' Type Axial Lead Items

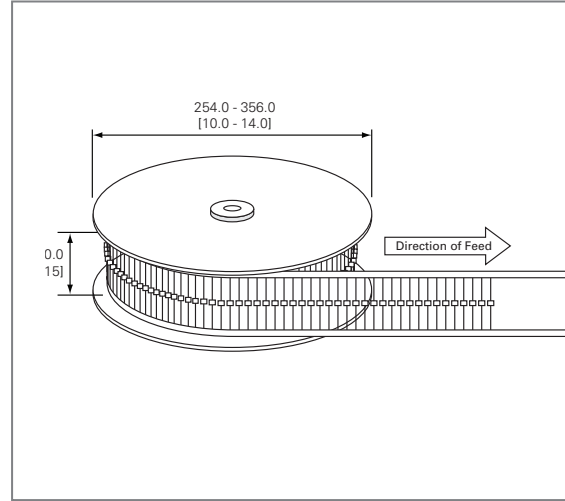
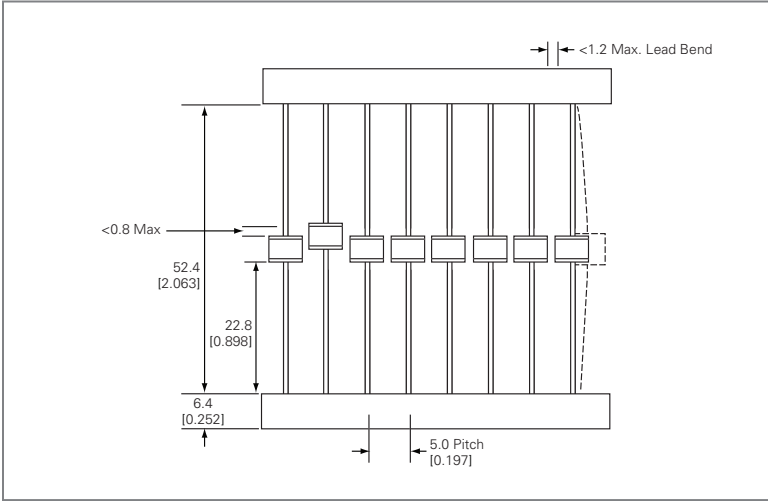

Core and 'MS' Type Items

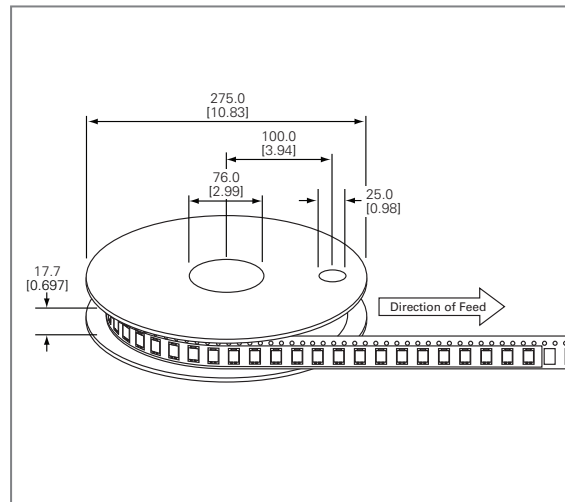
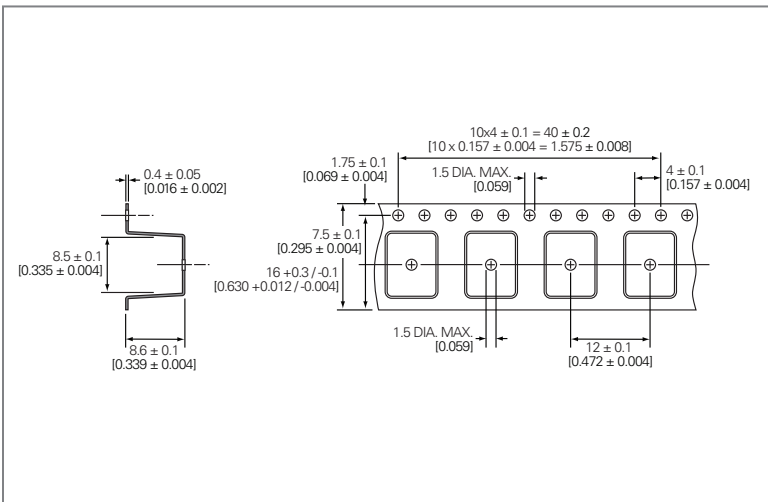

For 'LS' Type Shaped Lead Items

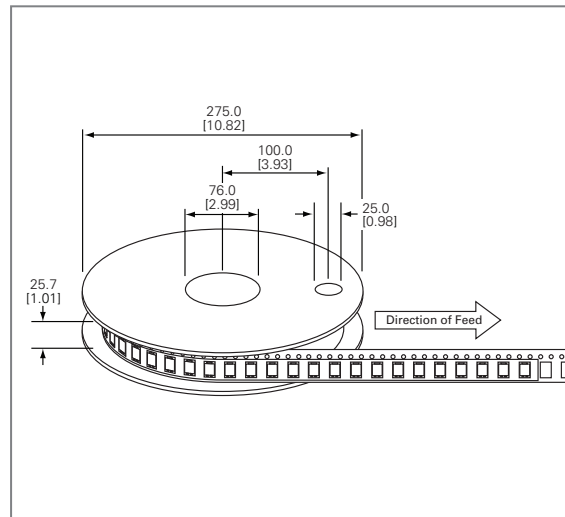
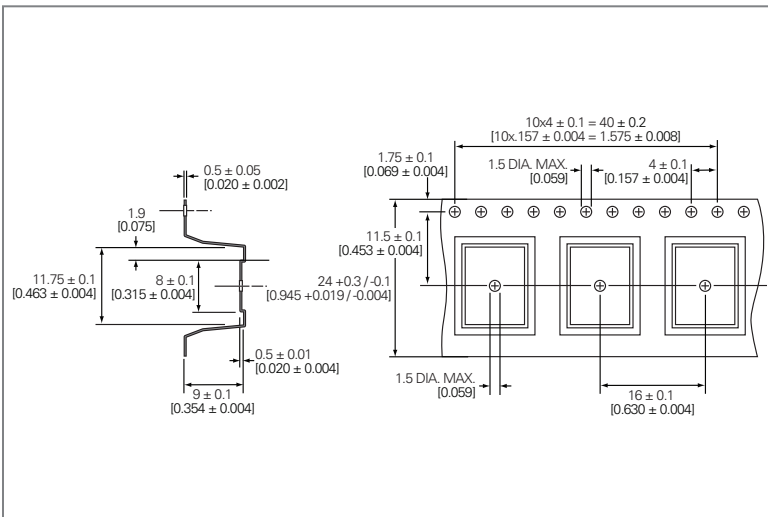

Part Numbering System and Ordering Information

CG2 XXX XX * XX

Series
CG – for 75, 90, or 110V
CG2 – for 145V to 1000V

Breakdown Voltage

75	300
90	350
110	470
145	600
230	800
250	1000

Lead Option Code
 (Blank) = No Leads / Core
L = Straight Leads
LS = Shaped Leads
MS = Surface Mount

Option Code*
 SN = denotes different DC Breakover Voltage Limit. Please refer to Electrical Characteristics table for additional information.

Packaging Option Code
 (Blank) = No Leads / Core, Bulk Bag - 400 pcs
 L(Blank) = Straight Lead, Tray - 50 pcs
LTR = Straight Lead, Tape & Reel per EIA RS-296-E - 500 per reel
LTE = Straight Lead, Tape & Reel per IEC 60286-1 - 500 per reel
 LS(Blank) = Shaped Lead (see LS dimensions), Tape & Reel - 500 per reel

Examples:

- CG75** – A non-leaded 75V device
- CG2230L** – A leaded 230V device
- CG2800LTR** – A leaded 800V device, tape-and-reel (per EIA standard RS-296-D)

Notes:

CG/CG2 devices with other breakdown voltages in the 75-1000 V range are available upon request.



Description

The SL1026 Series is a heavy-duty transient suppressor using Gas Plasma technology. In response to transients that exceed the device's breakover voltage, the device changes from a very high impedance state to a low impedance state to conduct harmful current away from the protected system. The SL1026 is designed to protect electrical and electronic equipment such as communications, control and railway systems. Carefully designed geometry ensures against short circuiting if a failure occurs due to conditions and events beyond the design criteria. Optional electrical mounting clip (part SL1053) is available to aid mounting and connection.

Agency Approvals

AGENCY	AGENCY FILE NUMBER
	E128662

3 Electrode GDT Graphical Symbol

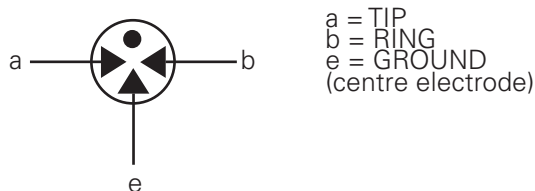

Features

- RoHS compliant
- 55 kA surge capability (single shot) tested with 8/20µS pulse as defined by IEC 61000-4-5
- 40 kA surge capability (repetitive)
- Will protect against Trapezoidal waveforms as specified in RIA 12.
- Will protect against capacitor discharge voltage transient waveforms as specified in RIA 12.
- Will protect against double exponential voltage transient waveforms as specified in IEC 571.

Applications

- Signaling equipment.
- Communication equipment
- Control gear.
- Trackside cabinets.
- Cell phone base stations

Electrical Characteristics

Part Number*	DC Voltage 100 V/sec		DC Voltage 1kV/µs	¹ AC Current 9 cycles @ 50-60Hz (Amps)	¹ AC Current 50Hz 1 sec x10 (Amps)	¹ Surge Current 8/20µSec x 10 (kAmps)	^{1,2} Max Single Surge 8/20µSec (kAmps)	¹ Max Single Surge 10/350µSec (kAmps)	¹ 150(+) and 150(-) 10/1000µSec (Amps)
	MIN	MAX							
SL1026-275	200	350	800	200	10	20	40	8	200
SL1026-400	300	500	900	200	10	20	40	8	200
SL1026-700	560	840	1300	200	10	20	40	8	200

NOTES:

End of life limits

– DC: 50% of minimum initial DC breakdown voltage limit to 150% of maximum initial DC breakdown voltage limit.

– Impulse: less than 150% of initial impulse breakdown voltage limit.

1. Total current through center electrode, tested using SL1053B-NL holder

2. Exceeds capability of SL1053B-NL holder

Voltage vs. Time Characteristic

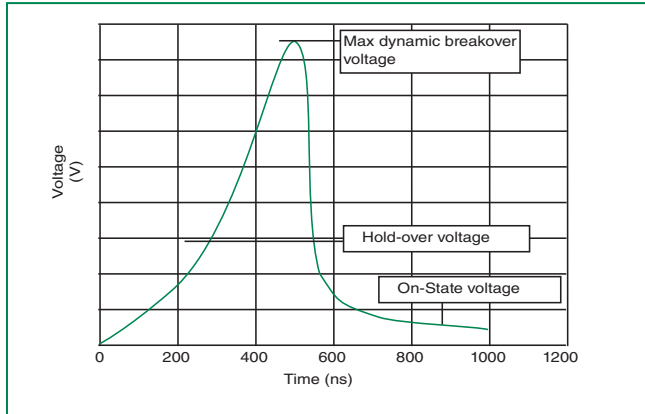

Electrical Specifications

Insulation Resistance	> 10GΩ at 100 Volts
Capacitance:	<=2.5pf, 1MHz 0 Volts Bias
Holdover Voltage:	<150mS, tested at 130 volts according to ITU-T Rec. K.12 & REA PE 80
Arc Voltage:	~35 Volts, On State Voltage at 1 Amp (Depending on Voltage Type)
Glow to Arc Transition Current:	~1 Amp
Glow Voltage:	> 150 Volts, depending on Voltage Type

Physical Specifications

Weight:	11g (0.388 oz.)
Materials:	Electrode Base: Nickel Iron Alloy Electrode Plating: Nickel Body: Ceramic
Part Marking:	Color coded body SL1026-275: Black/Black SL1026-400: Black/Yellow SL1026-700: Black/Red
Storage and Operating Temperature:	-40°C to +90°C

Product Dimensions

SL1026 GDT Series Profile

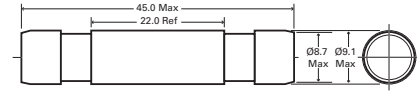

Type 1053 Holder Profile

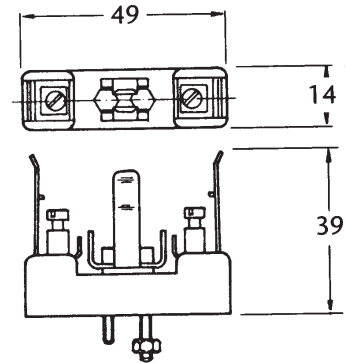

All dimensions in mm

Part Numbering System

SL 1026 | □ | □ | □ | □ | □
Voltage ————

Packaging

GDT devices are provided as bulk pack in poly bag – 20 pieces per bag and 5 bags per carton.

RoHS  **SL1002A Series**



Description

The Broadband Optimized™ SL1002A series has been especially developed for use in broadband equipment. Special design features provide high levels of protection against fast rising transients in the 100V/μs to 1kV/μs range usually caused by lightning disturbances. These devices have ultra low capacitance (typically 1.2pF or less) and present insignificant signal losses up to 1.5GHz. These devices are extremely robust and are able to divert a 5000A pulse without destruction. For AC Power Cross of long duration, overcurrent protection is recommended.

Agency Approvals

AGENCY	AGENCY FILE NUMBER
	E128662

2 Electrode GDT Graphical Symbol



Features

- RoHS compliant/Lead-free
- Ultra low insertion loss
- Surface mountable
- 5kA surge capability tested with 8/20μS–Pulse as defined by IEC 61000-4-5
- Excellent response to fast rising transients
- Can be used to meet Telcordia GR1089 without series resistance
- 10/700 6kV capability, as per ITU-T Rec. K.21, enhanced test level
- 2000 A 2/10μs surge rating
- Meet FCC part 68 10/160μs waveform, 200A test and 10/560μs waveform 100A test
- Halogen-free

Applications

- Broadband equipment
- ADSL equipment
- XDSL equipment
- Satellite and CATV equipment
- General telecom equipment

Electrical Characteristics

Part Number	Device Specifications (at 25°C)							Life Ratings						
	DC Breakdown in Volts ^{1,2} (@100V/s)			Impulse Breakdown in Volts ^{3,4} (@100V/μs)	Impulse Breakdown in Volts ^{3,4} (@1kV/μs)	Insulation Resistance	Capacitance (@1MHz 0V Bias)	Arc Voltage (on state voltage) @1Amp Min	Surge Life (@100A 10/1000μs)	Nominal Impulse Discharge Current (@20μs)	Nominal AC Discharge Current (10x1s @50-60Hz)	DC Holdover Voltage ⁵	Max Impulse Discharge Current (1 Application)	
	MIN	TYP	MAX	MAX		MIN	MAX	TYP				TYP	@ 2/10 μs	@ 10/350 μs
SL1002A075	60	75	90	400	650	10 ⁹ Ω (at 50V)	1.2 pF	~15 V	300 shots ⁶	10 shots ⁷ (@ 5kA)	5 A	50 V	2 kA	1.5 kA
SL1002A090	72	90	108											
SL1002A230	184	230	276	600	700	10 ⁹ Ω (at 100V)	1.2 pF	~15 V	300 shots ⁶	10 shots ⁷ (@ 5kA)	5 A	135 V	2 kA	1.5 kA
SL1002A250	200	250	300											
SL1002A260	210	260	310											
SL1002A350	280	350	420											
SL1002A470	376	470	564											
SL1002A600	480	600	720	1100	1200	10 ⁹ Ω (at 500V)	1.2 pF	~15 V	300 shots ⁶	10 shots ⁷ (@ 5kA)	5 A	135 V	2 kA	1.5 kA
SL1002A600SP	570	600	780	1200	1300									

Notes:

- At delivery AQL 0.65 level II, DIN ISO 2859
- In ionized mode
- In ionized mode, tested according to ITU-T Rec. K.12
- Comparable to the silicon measurement Switching Voltage (Vs)
- Reference REA PE-80, 0.2A. Tested to ITU-T Rec. K.12 and REA PE-80 < 150 msec.
- 300 Applications [150(+) & 150(-)]
- 10x[5x (+) & 5x (-)] Applications

Product Characteristics

Materials	Construction = Ceramic Insulator Device Finish = Dull Tin-plated 17.5 +/-12.5 microns
Product Marking	Littelfuse 'LF' Mark, voltage and date code

Glow to Arc Transition Current	< 0.5 Amps
Glow Voltage	~60 - 140 Volts
Storage and Operational Temperature	-40 to +90°C

Voltage vs. Time Characteristics

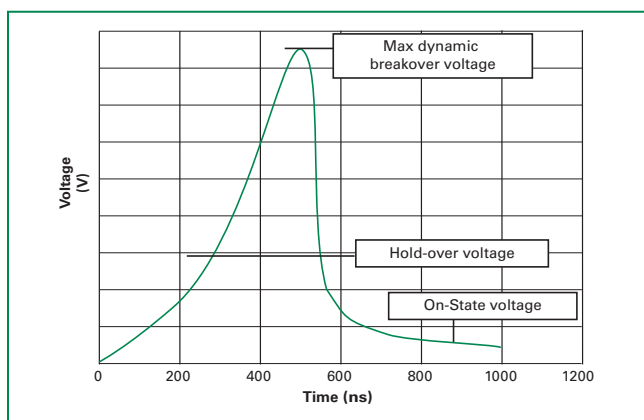

Insertion Loss Characteristics

Typical Insertion Loss Characteristics (90V)

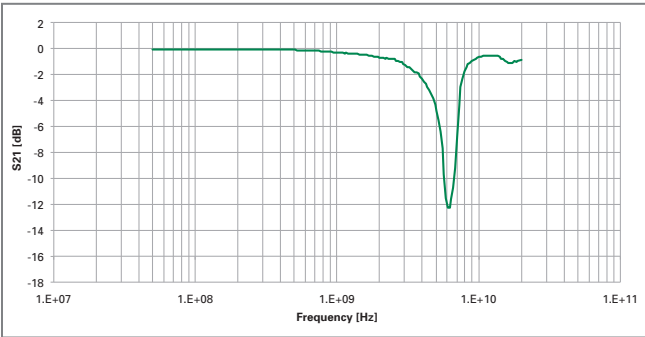

Typical Insertion Loss Characteristics (600V)

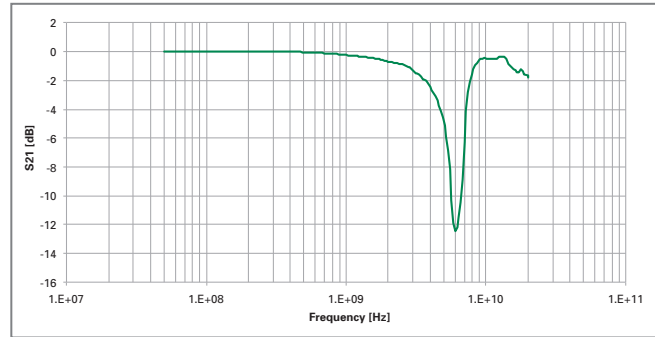

Device Dimensions

'C' Type Core Devices

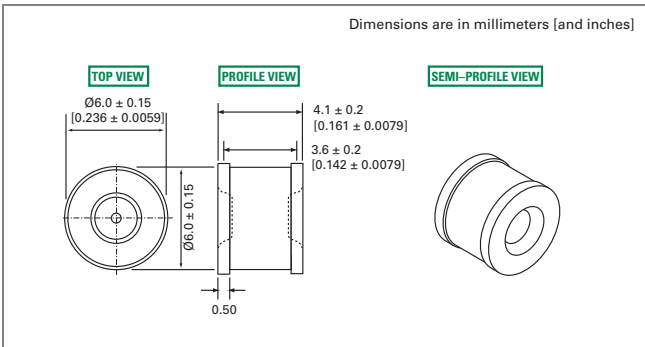

'SM' Type Surface Mount Devices

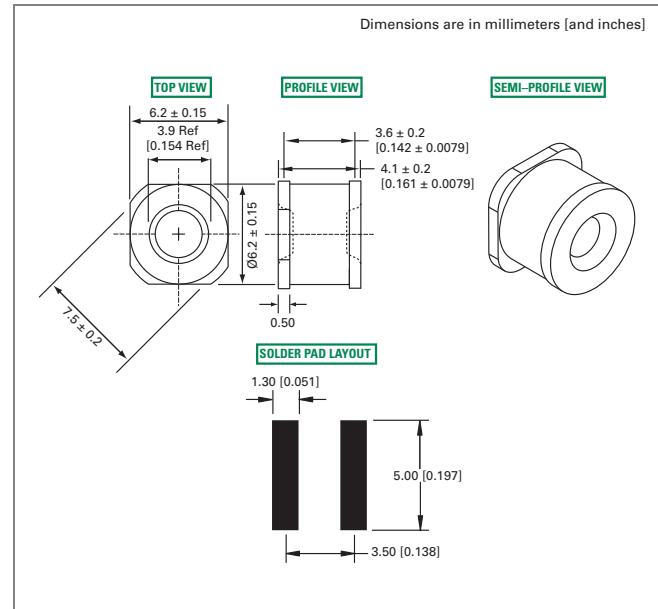

Soldering Parameters - Reflow Soldering (Surface Mount Devices)

Reflow Condition		Pb-free assembly
Pre Heat	- Temperature Min ($T_{s(min)}$)	150°C
	- Temperature Max ($T_{s(max)}$)	200°C
	- Time (Min to Max) (t_s)	60 – 180 seconds
Average Ramp-up Rate (Liquidus Temp (T_L) to peak)		3°C/second max.
$T_{s(max)}$ to T_L - Ramp-up Rate		5°C/second max.
Reflow	- Temperature (T_L) (Liquidus)	217°C
	- Temperature (t_L)	60 – 150 seconds
Peak Temperature (T_p)		260 ^{+0/-5} °C
Time within 5°C of Actual Peak Temperature (t_p)		10 – 30 seconds
Ramp-down Rate		6°C/second max.
Time 25°C to Peak Temperature (T_p)		8 minutes max.
Do not exceed		260°C

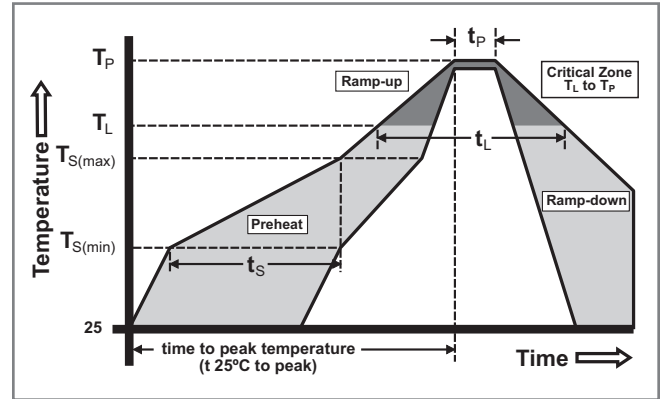

Soldering Parameters - Wave Soldering (Thru-Hole Devices)

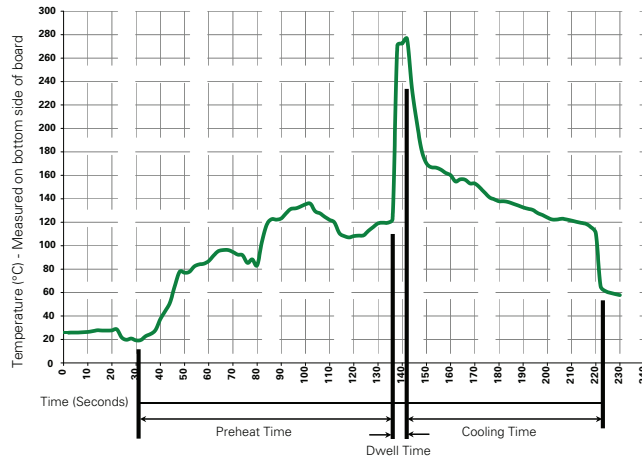

Recommended Process Parameters:

Wave Parameter	Lead-Free Recommendation
Preheat: (Depends on Flux Activation Temperature) (Typical Industry Recommendation)	
Temperature Minimum:	100° C
Temperature Maximum:	150° C
Preheat Time:	60-180 seconds
Solder Pot Temperature:	280° C Maximum
Solder Dwell Time:	2-5 seconds

Soldering Parameters - Hand Soldering

Solder Iron Temperature: 350° C +/- 5°C
 Heating Time: 5 seconds max.

Packaging

'C' Type Core Items: Package bulk pack in polybag, 1000 pcs/bag

'SM' Type Surface Mount Items: Packaged tape and reel carrier, 1000 pcs/reel (specifications below)

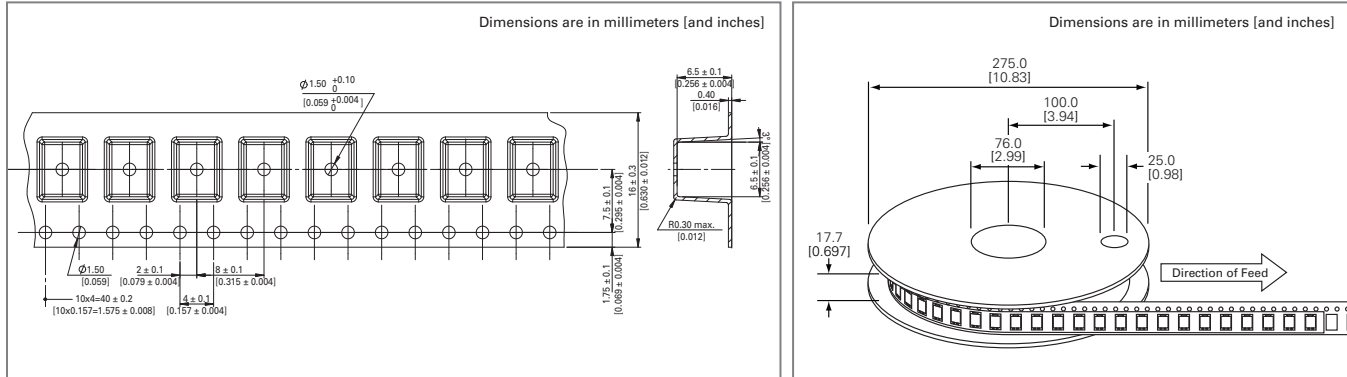

Part Numbering System and Ordering Information

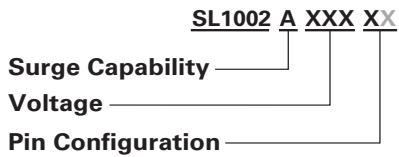

- C** = Core (Packed in polybag, 1000pcs/bag)
- SM** = Surface Mount (Packed in carrier and tape, 1000pcs/reel)

RoHS  **SL1003A Series**



Description

The SL1003A series has been especially developed for Broadband equipment. Special design features provide high levels of protection against fast rising transients in the 100V/μs to 1kV/μs range usually caused by lightning disturbances.

These devices have ultra low capacitance 1.5pF and present insignificant signal losses up to 1.5GHz. These devices are extremely robust and are able to divert a 5000A pulse without destruction. For AC Power Cross of long duration, over-current protection is recommended.

Agency Approvals

AGENCY	AGENCY FILE NUMBER
	E128662

3 Electrode GDT Graphical Symbol



Features

- RoHS compliant
- Low insertion loss
- Surface mountable
- 5kA surge capability tested with 8/20/μs pulse as defined by IEC 61000-4-5
- GHz working frequency
- Excellent response to fast rising transients
- Can be used to meet Telcordia GR1089 without series resistance
- 10/700 6kV capability, as per ITU-Tk.21, enhanced test level
- 2000 Amp 2/10μs surge rating

Applications

- Broadband equipment
- ADSL equipment
- XDSL equipment
- Satellite and CATV equipment
- General telecom equipment

Electrical Characteristics

Part Number	Device Specifications (at 25°C)								Life Ratings												
	DC Breakdown in Volts ^{1,2,3} (@100V/s)			Impulse Breakdown in Volts ^{2,3} (@100V/μs)	Impulse Breakdown In Volts ^{2,3} (@1kV/μs)	Insulation Resistance	Capacitance (@1MHz 0V Bias)	Arc Voltage (on state Voltage) @1Amp Min	Surge Life (@200A 10/1000μs)	Nominal Impulse Discharge Current (8/20μs)	Nominal AC Discharge Current (10x1s @50Hz)	AC Discharge Current (9 Cycles @ 50Hz)	DC Holdover Voltage ⁴	Max Impulse Discharge Current (1 Application)							
	MIN	TYP	MAX	MAX		MIN	MAX	TYP					TYP	@ 10/350μs							
SL1003A090	72	90	108	600	700	10 ⁹ Ω (at 50V)	1.5 pF	~10 to 35 V	300 shots	10 shots (@10kA)	10 A	30 A	50 V	2 kA							
SL1003A230	184	230	276																		
SL1003A250	200	250	300																		
SL1003A260	210	260	310			750															
SL1003A300	240	300	360		750	850							10 ⁹ Ω (at 100V)								
SL1003A350	280	350	420		800	900															
SL1003A400	320	400	480		850	950															
SL1003A450	360	450	540		900	1000															
SL1003A500	400	500	600	1100	1400																

Notes:

1. At delivery AQL 0.65 level II, DIN ISO 2859
2. In ionized mode, tested according to ITU-T Rec. K.12
3. Comparable to the silicon measurement Switching Voltage (Vs)
4. Reference REA PE-80, 0.2A. Tested to ITU-T Rec. K.12 and REA PE-80 < 150 msec.

Product Characteristics

Materials	Leaded Device: Nickel-plated with Tin-plated wires Core and Surface Mount: Dull Tin-plated
Product Marking	Littelfuse 'LF' Mark, voltage and date code

Glow to Arc Transition Current	~1 Amp
Glow Voltage	~60 to 200 Volts
Storage and Operational Temperature	-40 to +90°C

Device Dimensions

For SL1003A series:

Dimensions are in millimeters [and inches]

'R' Type Radial Lead Devices (SL1003AxxxR-001)

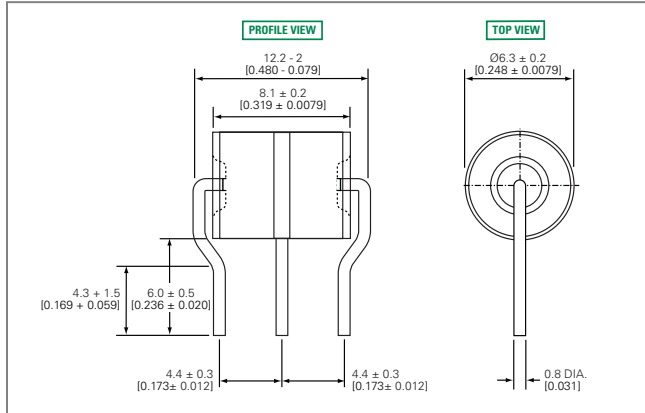

'C' Type Core Devices

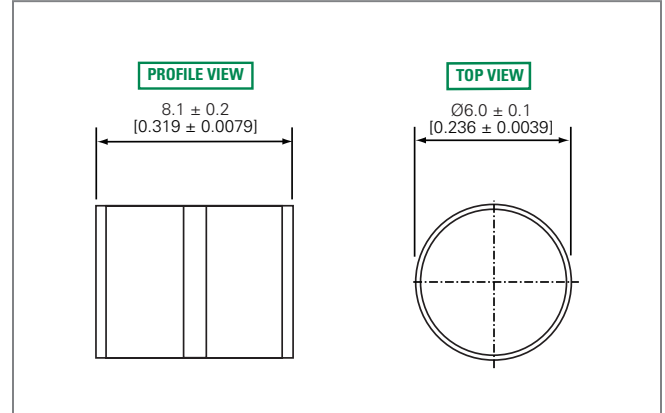

'R' Type Radial Lead Devices (SL1003AxxxR and SL1003AxxxRF)

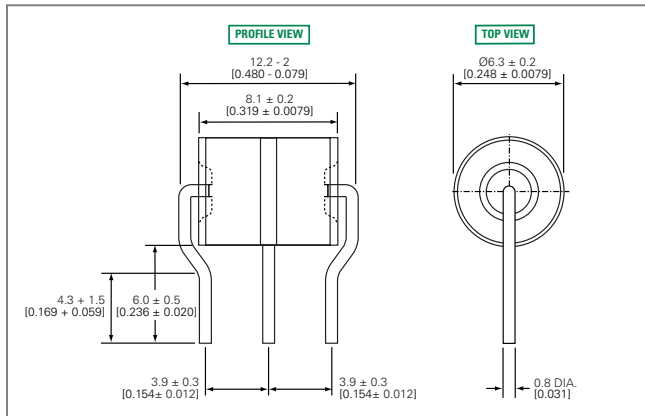

'SM' Type Surface Mount Devices

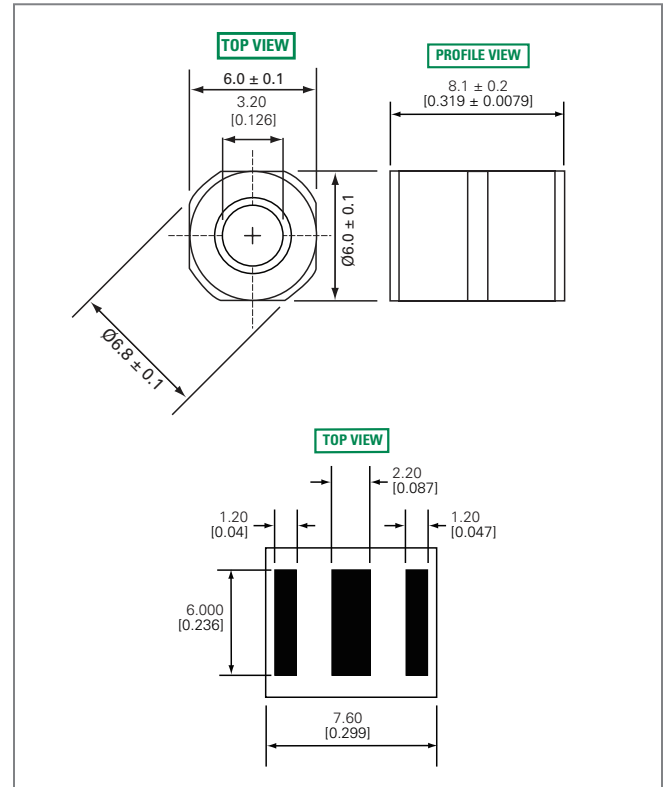

Soldering Parameters - Reflow Soldering (Surface Mount Devices)

Reflow Condition		Pb-free assembly
Pre Heat	- Temperature Min ($T_{s(min)}$)	150°C
	- Temperature Max ($T_{s(max)}$)	200°C
	- Time (Min to Max) (t_s)	60 – 180 seconds
Average Ramp-up Rate (Liquidus Temp (T_L) to peak)		3°C/second max.
$T_{s(max)}$ to T_L - Ramp-up Rate		5°C/second max.
Reflow	- Temperature (T_L) (Liquidus)	217°C
	- Temperature (t_L)	60 – 150 seconds
Peak Temperature (T_p)		260 ^{+0/-5} °C
Time within 5°C of Actual Peak Temperature (t_p)		10 – 30 seconds
Ramp-down Rate		6°C/second max.
Time 25°C to Peak Temperature (T_p)		8 minutes max.
Do not exceed		260°C

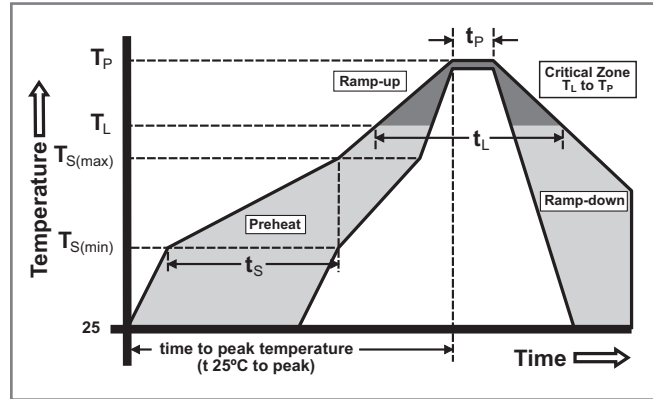

Soldering Parameters - Wave Soldering (Thru-Hole Devices)

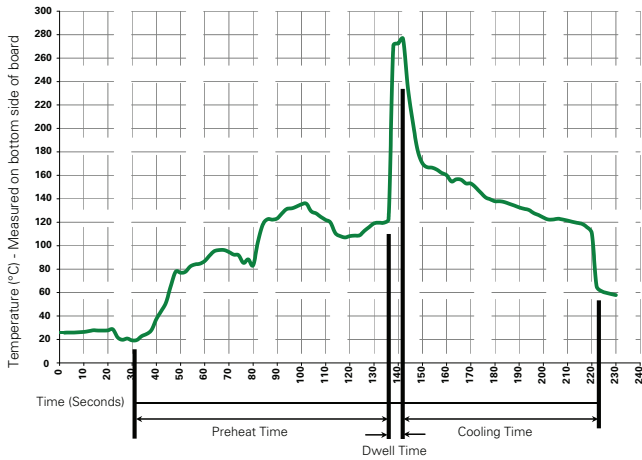

Recommended Process Parameters:

Wave Parameter	Lead-Free Recommendation
Preheat:	
(Depends on Flux Activation Temperature)	(Typical Industry Recommendation)
Temperature Minimum:	100° C
Temperature Maximum:	150° C
Preheat Time:	60-180 seconds
Solder Pot Temperature:	280° C Maximum
Solder Dwell Time:	2-5 seconds

Soldering Parameters - Hand Soldering

Solder Iron Temperature: 350° C +/- 5°C
 Heating Time: 5 seconds max.

Packaging

'C' Type Core Items: Package bulk pack in polybag, 500 pcs/bag

'R' and 'RF' Type Radial Lead Items: Packed in tray, 100 pcs/tray

'SM' Type Surface Mount Items: Packaged tape and reel carrier, 700 pcs/reel (specifications below)

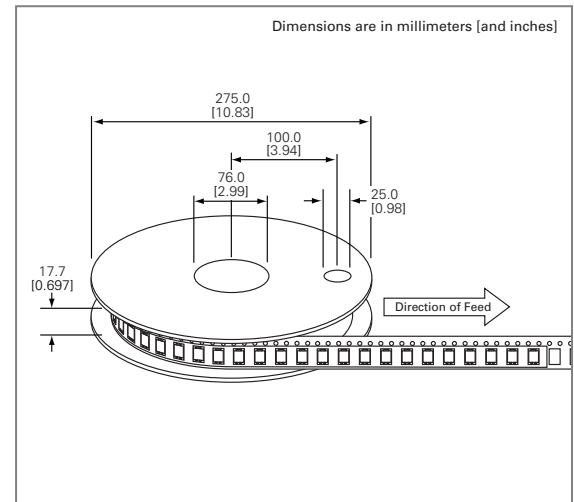
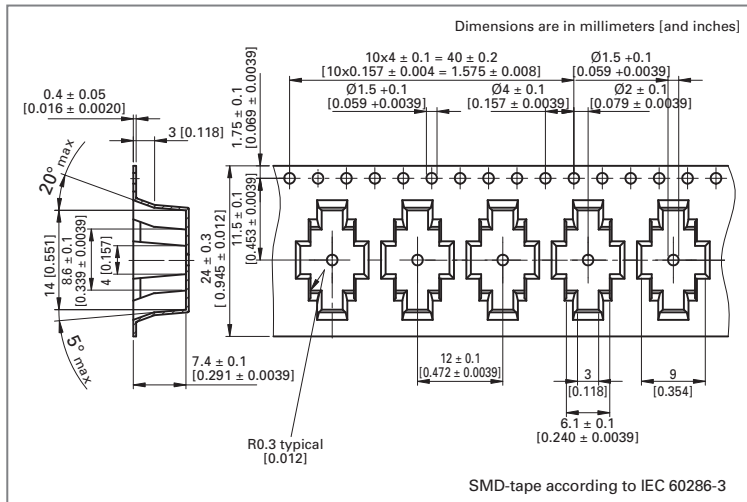

Part Numbering System and Ordering Information

SL1003 A XXX XX

Type 3 Pole Arrestor

Voltage

Pin Configuration

- C** = Core type (Packed in polybag, 500pcs/bag)
- R** = Radial Lead without Failsafe (Packed in tray, 100pcs/tray)
- RF** = Radial Lead with Failsafe (Packed in tray, 100pcs/tray)
- SM** = Surface Mount (Packed in carrier and tape, 700pcs/reel)

RoHS SL1122A Series Hybrid



Description

The SL1122A series Hybrid features a high performance Alpha Gas Plasma Tube in conjunction with a MOV. These devices are matched so that high speed pulses are initially clamped by the MOV, then as the current rises, the transient energy is switched through the gas tube. The Hybrid offers high levels of performance on fast rising transients in the domain of 100V/μs to 10 kV/μs, so eliminates the dv/dt switching delay normally exhibited by standard GDTs. These devices are extremely robust and are able to divert a 10,000 Amp pulse without destruction.

Agency Approvals

AGENCY	AGENCY FILE NUMBER
	E128662

2 Electrode GDT Graphical Symbol

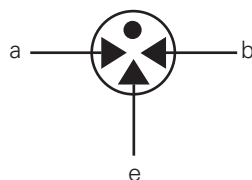

a = TIP
b = RING
e = GROUND
(centre electrode)

Features

- RoHs Compliant
- Excellent response to fast rising transients
- Flat response up to 10kV/μs
- 10kA surge capability tested with 8/20μs pulse as defined by IEC 61000-4-5
- Thermal failsafe

Applications

- MDF protection
- ADSL equipment
- XDSL equipment
- Alarm panels
- General telecom equipment

Electrical Characteristics

Part Number	Device Specifications (at 25°C)						Life Ratings				
	DC Breakdown in Volts ^{1,2} (@100V/s)			DC Voltage ² (1kV/μs Ignition Time)	Insulation Resistance	Capacitance (@1MHz, 0V bias, 1V oscillation)	Arc Voltage (on state voltage) @1Amp Min	Surge Life ¹ (10/1000μs 300x +/-)	Surge Current ¹ (8/20μs x 10)	Nominal AC Discharge Current ¹ (10x1s@50Hz)	DC Holdover Voltage (<150msecs.)
	MIN	TYP	MAX		MIN	MAX	TYP			TYP	
SL1122A090	72	90	108	200 (< 10μs)	> 10 ⁸ Ω (at 50V)	270 pF	~10 to 35 Volts	200 A	10 kA	10 A	50 V
SL1122A230	184	230	276	350 (< 10μs)	> 10 ⁸ Ω (at 100V)	100 pF					135 V
SL1122A260	210	260	310	400 (< 10μs)							

Tested in accordance with ITU-T Rec K.12

Notes:
1. Total current through centre electrode
2. Maximum Peak Break Over Voltage

Product Characteristics

Materials	Electrode Base: Nickel Iron Alloy Electrode Plating: Bright Tin Body: Ceramic
Product Marking	Littelfuse 'LF' Mark, voltage and date code. Red.

Glow to Arc Transition Current	~1 Amp
Glow Voltage	~60 to 200 Volts
Storage and Operational Temperature	-40 to +90°C
Transverse Voltage (Delay Time)	< 0.2 μSec. (Tested to ITU-T Rec.K.12)

Device Dimensions

Radial Lead Devices

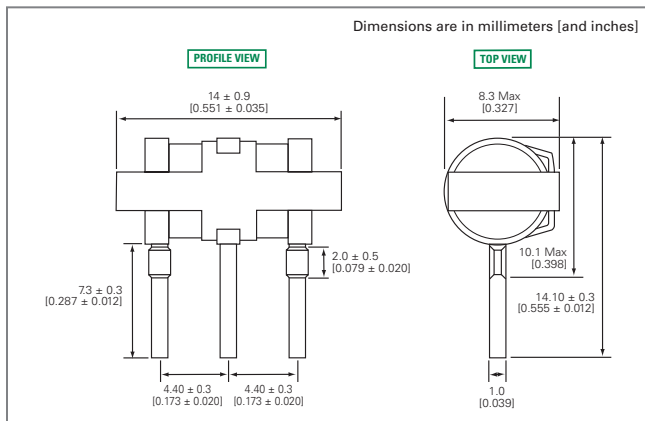

Packaging Dimensions

For Radial Lead Items: Packed in tray (100 pcs)

Part Numbering System and Ordering Information



Soldering Parameters - Reflow Soldering

Reflow Condition		Pb-free assembly
Pre Heat	- Temperature Min ($T_{s(min)}$)	150°C
	- Temperature Max ($T_{s(max)}$)	200°C
	- Time (Min to Max) (t_s)	60 – 180 seconds
Average Ramp-up Rate (Liquidus Temp (T_L) to peak)		3°C/second max.
$T_{s(max)}$ to T_L - Ramp-up Rate		5°C/second max.
Reflow	- Temperature (T_L) (Liquidus)	217°C
	- Temperature (t_L)	60 – 150 seconds
Peak Temperature (T_p)		260 ^{+0/-5} °C
Time within 5°C of Actual Peak Temperature (t_p)		10 – 30 seconds
Ramp-down Rate		6°C/second max.
Time 25°C to Peak Temperature (T_p)		8 minutes max.
Do not exceed		260°C

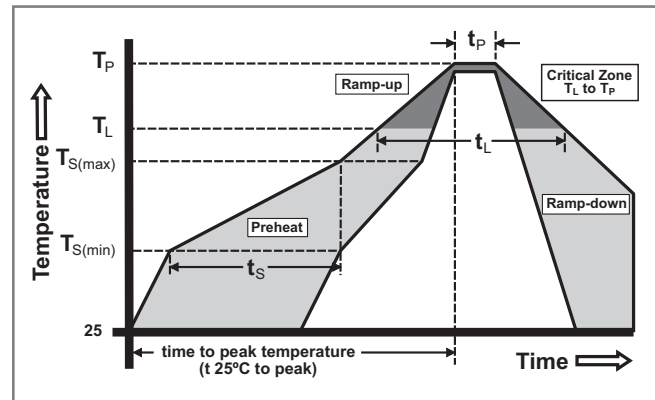

* Devices that are soldered require inspection before use.

Soldering Parameters - Wave Soldering (Thru-Hole Devices)

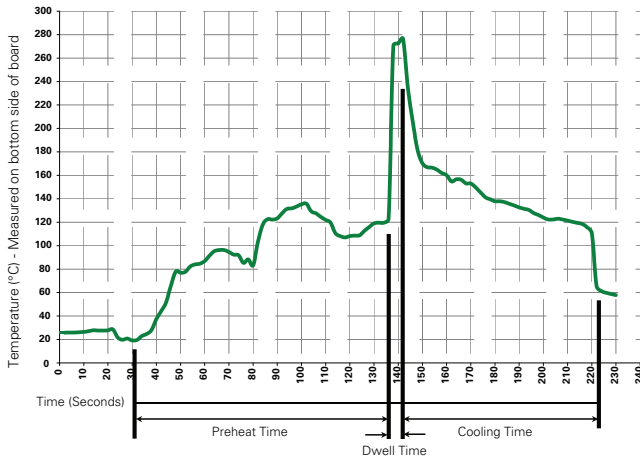

Recommended Process Parameters:

Wave Parameter	Lead-Free Recommendation
Preheat: (Depends on Flux Activation Temperature) (Typical Industry Recommendation)	
Temperature Minimum:	100° C
Temperature Maximum:	150° C
Preheat Time:	60-180 seconds
Solder Pot Temperature:	280° C Maximum
Solder Dwell Time:	2-5 seconds

Soldering Parameters - Hand Soldering

Solder Iron Temperature: 350° C +/- 5°C
 Heating Time: 5 seconds max.

RoHS  **SL1011A/B and SL1411A Series**

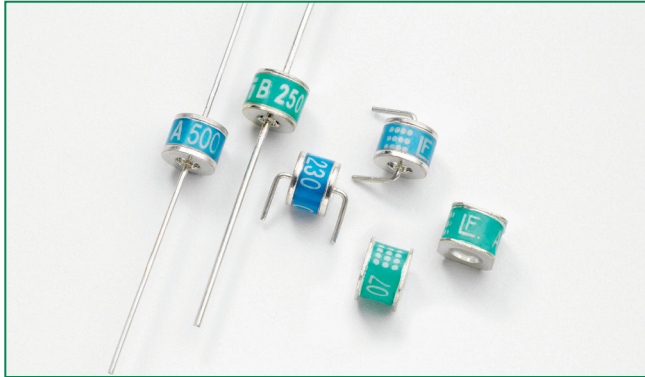

Description

The SL1011A/B and SL1411A series provides high levels of protection against fast rising transients in the 100V/μs to 1kV/μs range usually caused by lightning disturbances.

The SL1011A/B and SL1411A series offers low capacitance (< 1.5pf) which provides low insertion loss at high frequencies.

SL1011A offers 5kA protection without destruction whereas the SL1011B and SL1411A offer 10kA surge protection without destruction (maximum single surge of 12kA @ 8/20μs).

Agency Approvals

AGENCY	AGENCY FILE NUMBER
	E128662

2 Electrode GDT Graphical Symbol



Features

- RoHS compliant
- Low insertion loss
- Excellent response to fast rising transients
- Ultra low capacitance
- 5kA (SL1011A) or 10kA (SL1011B & SL1411A) surge capability tested with 8/20μs pulse as defined by IEC 61000-4-5

Applications

- Broadband equipment
- ADSL equipment
- XDSL equipment
- Satellite and CATV equipment
- General telecom equipment

Electrical Characteristics

Part Number	Device Specifications (at 25°C)								Life Ratings																																				
	DC Breakdown in Volts ^{1,2} (@100V/s)			Impulse Breakdown in Volts ³ (@100V/μs)	Impulse Breakdown In Volts (@1kV/μs)	Insulation Resistance	Capacitance (@1MHz)	Arc Voltage (on state Voltage) @1Amp Min	Surge Life (@100A 10/1000μs)	Nominal Impulse Discharge Current (@20μs)	Nominal AC Discharge Current (10x1s @50-60Hz)	AC Discharge Current (9 Cycles @ 50Hz)	DC Holdover Voltage ⁴	Max Impulse Discharge Current (1 Application)																															
	MIN	TYP	MAX	MAX		MIN	MAX	TYP					TYP	@ 8/20μs	@ 10/350μs																														
SL1011A075	60	75	90	500	700	10 ¹⁰ Ω (at 50V)	1.5 pF	~20 V	300 shots	SL1011A: 10 shots (@5kA)	SL1011A: 5 A	SL1011A: 20 A	50 V	SL1011B & SL1411A: 12 kA	1 kA																														
SL1011B075																																													
SL1411A075	72	90	108	500	600											10 ¹⁰ Ω (at 100V)	1.5 pF	~20 V	300 shots	SL1011B & SL1411A: 10 shots (@10kA)	SL1011B & SL1411A: 10 A	SL1011B & SL1411A: 65 A	135 V	SL1011B & SL1411A: 12 kA	1 kA																				
SL1011A090																																													
SL1011B090																																													
SL1411A090																																													
SL1011A145	116	145	174	500	650																					10 ¹⁰ Ω (at 100V)	1.5 pF	~20 V	300 shots	SL1011B & SL1411A: 10 shots (@10kA)	SL1011B & SL1411A: 10 A	SL1011B & SL1411A: 65 A	135 V	SL1011B & SL1411A: 12 kA	1 kA										
SL1011B145																																													
SL1011A150	120	150	180	500	650																															10 ¹⁰ Ω (at 100V)	1.5 pF	~20 V	300 shots	SL1011B & SL1411A: 10 shots (@10kA)	SL1011B & SL1411A: 10 A	SL1011B & SL1411A: 65 A	135 V	SL1011B & SL1411A: 12 kA	1 kA
SL1011B150																																													
SL1011A230	184	230	276	550	700	10 ¹⁰ Ω (at 100V)	1.5 pF	~20 V	300 shots	SL1011B & SL1411A: 10 shots (@10kA)	SL1011B & SL1411A: 10 A	SL1011B & SL1411A: 65 A	135 V	SL1011B & SL1411A: 12 kA	1 kA																														
SL1011B230																																													
SL1411A230	200	250	300	600	800											10 ¹⁰ Ω (at 100V)	1.5 pF	~20 V	300 shots	SL1011B & SL1411A: 10 shots (@10kA)	SL1011B & SL1411A: 10 A	SL1011B & SL1411A: 65 A	135 V	SL1011B & SL1411A: 12 kA	1 kA																				
SL1011A250																																													
SL1011B250																																													
SL1411A250																																													
SL1011A260	210	260	310	600	800																					10 ¹⁰ Ω (at 100V)	1.5 pF	~20 V	300 shots	SL1011B & SL1411A: 10 shots (@10kA)	SL1011B & SL1411A: 10 A	SL1011B & SL1411A: 65 A	135 V	SL1011B & SL1411A: 12 kA	1 kA										
SL1011B260																																													
SL1011A350	280	350	420	800	900																															10 ¹⁰ Ω (at 100V)	1.5 pF	~20 V	300 shots	SL1011B & SL1411A: 10 shots (@10kA)	SL1011B & SL1411A: 10 A	SL1011B & SL1411A: 65 A	135 V	SL1011B & SL1411A: 12 kA	1 kA
SL1011B350																																													
SL1411A350	376	470	564	1000	1100	10 ¹⁰ Ω (at 100V)	1.5 pF	~20 V	300 shots	SL1011B & SL1411A: 10 shots (@10kA)	SL1011B & SL1411A: 10 A	SL1011B & SL1411A: 65 A	135 V	SL1011B & SL1411A: 12 kA	1 kA																														
SL1011A470																																													
SL1411A470																																													
SL1011A500	400	500	600	1100	1200											10 ¹⁰ Ω (at 100V)	1.5 pF	~20 V	300 shots	SL1011B & SL1411A: 10 shots (@10kA)	SL1011B & SL1411A: 10 A	SL1011B & SL1411A: 65 A	135 V	SL1011B & SL1411A: 12 kA	1 kA																				
SL1011A600																																													
SL1411A600	480	600	720	1200	1400																																								
SL1011A600																																													

- Notes:
- At delivery AQL 0.65 level II, DIN ISO 2859
 - In ionized mode
 - Comparable to the silicon measurement Switching Voltage (Vs)
 - Tested according to ITU-T Rec. K.12 < 150 msec.

Product Characteristics

Materials	Leaded Device: Nickel-plated with Tin-plated wires Core and Surface Mount: Dull Tin-plated
Product Marking	Littelfuse 'LF' Mark, voltage and date code

Glow to Arc Transition Current	< 0.5 Amps
Glow Voltage	~60 Volts
Storage and Operational Temperature	-40 to +90°C

Device Dimensions

For SL1011A/SL1011B series:

'A' Type Axial Lead Devices

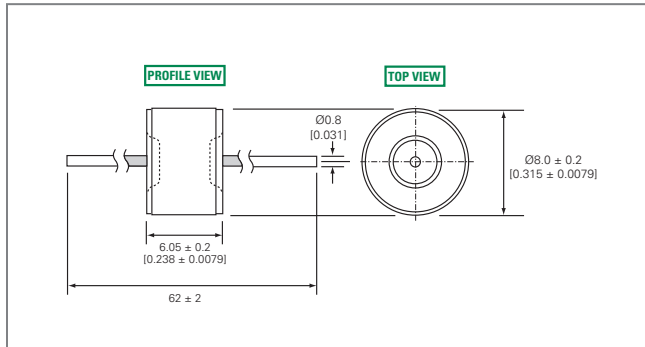

'C' Type Core Devices

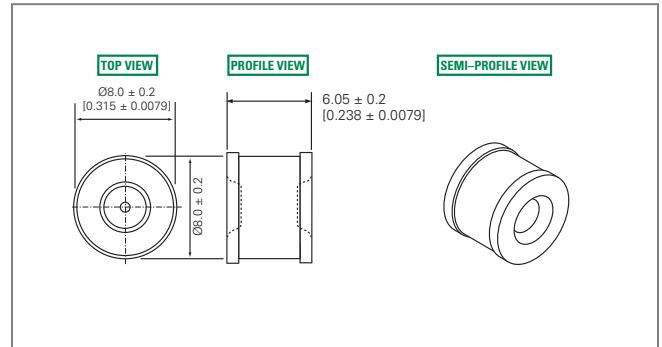

For SL1411A series:

'A' Type Axial Lead Devices

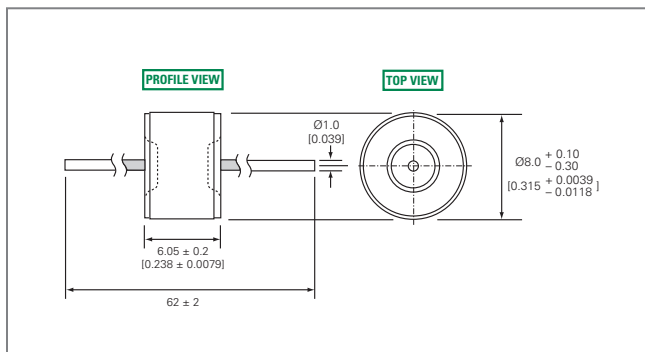

'SM' Type Surface Mount Devices

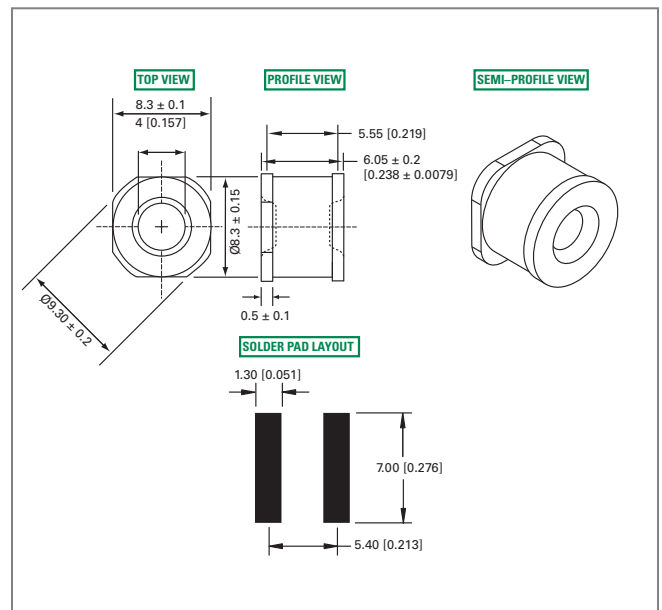

'C' Type Core Devices

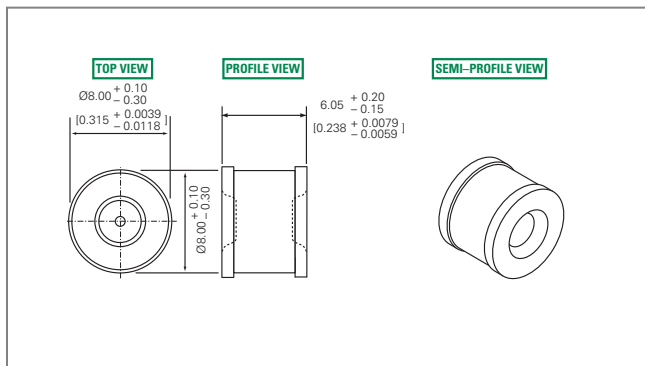

Soldering Parameters - Reflow Soldering (Surface Mount Devices)

Reflow Condition		Pb-free assembly
Pre Heat	- Temperature Min ($T_{s(min)}$)	150°C
	- Temperature Max ($T_{s(max)}$)	200°C
	- Time (Min to Max) (t_s)	60 – 180 seconds
Average Ramp-up Rate (Liquidus Temp (T_L) to peak)		3°C/second max.
$T_{s(max)}$ to T_L - Ramp-up Rate		5°C/second max.
Reflow	- Temperature (T_L) (Liquidus)	217°C
	- Temperature (t_L)	60 – 150 seconds
Peak Temperature (T_p)		260 ^{+0/-5} °C
Time within 5°C of Actual Peak Temperature (t_p)		10 – 30 seconds
Ramp-down Rate		6°C/second max.
Time 25°C to Peak Temperature (T_p)		8 minutes max.
Do not exceed		260°C

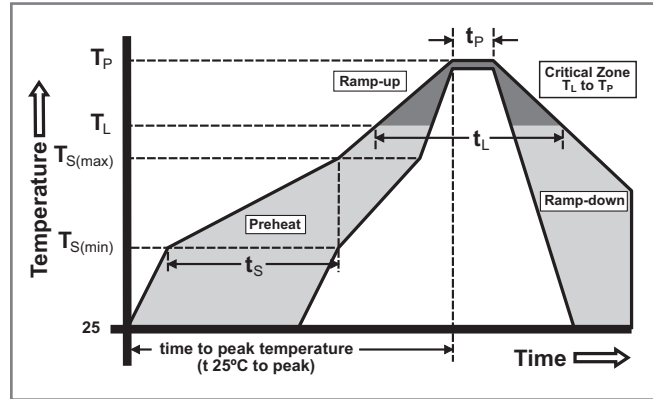

Soldering Parameters - Wave Soldering (Thru-Hole Devices)

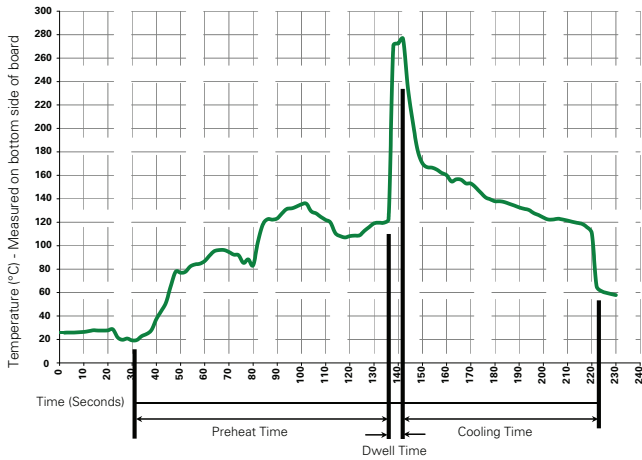

Recommended Process Parameters:

Wave Parameter	Lead-Free Recommendation
Preheat:	
(Depends on Flux Activation Temperature)	(Typical Industry Recommendation)
Temperature Minimum:	100° C
Temperature Maximum:	150° C
Preheat Time:	60-180 seconds
Solder Pot Temperature:	280° C Maximum
Solder Dwell Time:	2-5 seconds

Soldering Parameters - Hand Soldering

Solder Iron Temperature: 350° C +/- 5°C
 Heating Time: 5 seconds max.

Packaging Dimensions

For 'A' Type Axial Lead Items

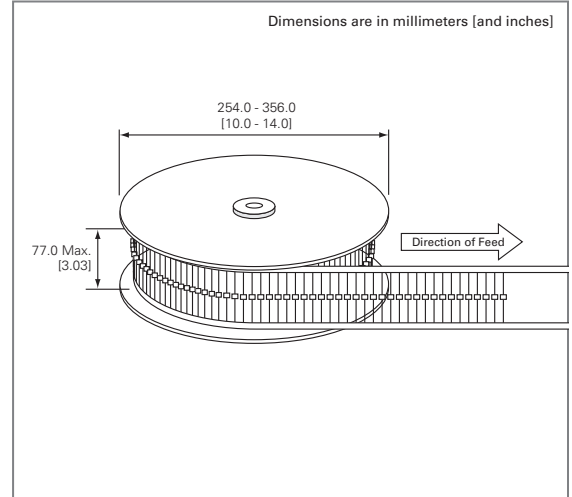
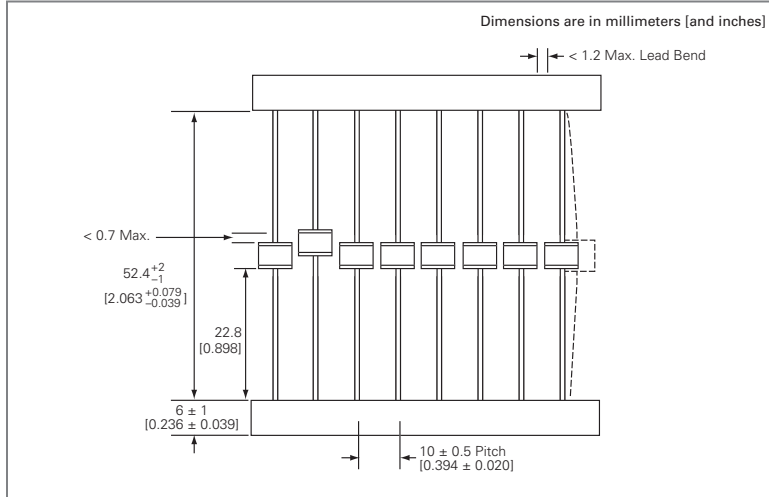

For 'SM' Type Surface Mount Items (SL1411A series only)

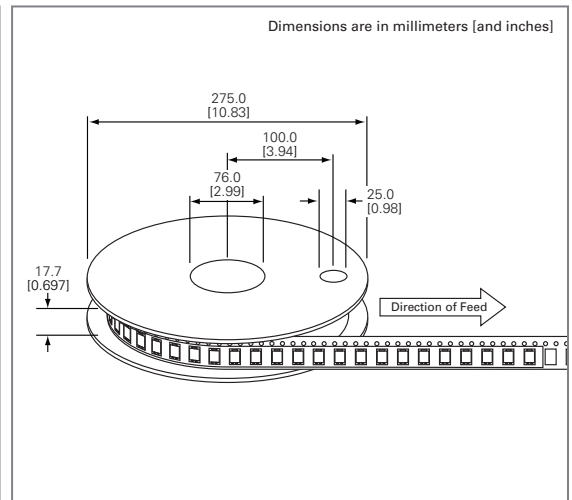
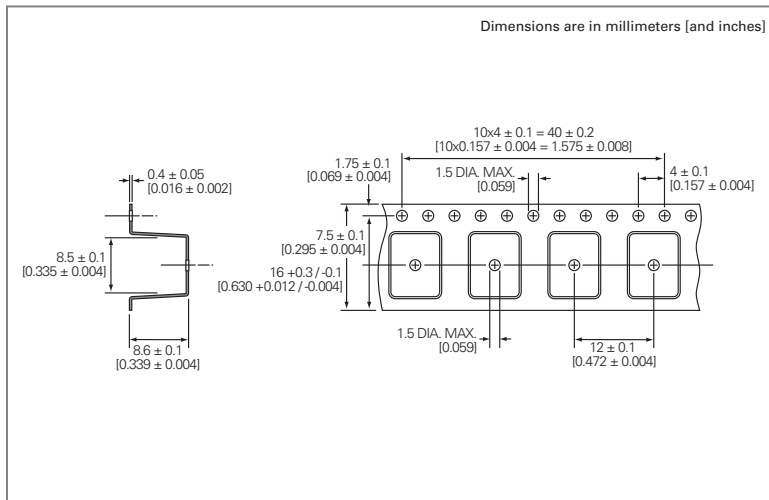

For 'C' Type Core Items: Packed in plastic bag (500 pcs)

Part Numbering System and Ordering Information

For SL1011A series:

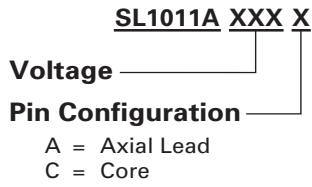

Remarks: Formed leads are available on request

For SL1011B series:

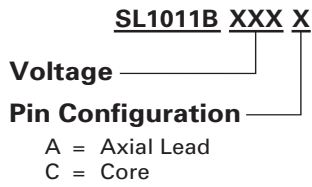

Remarks: Formed leads are available on request

For SL1411A series:

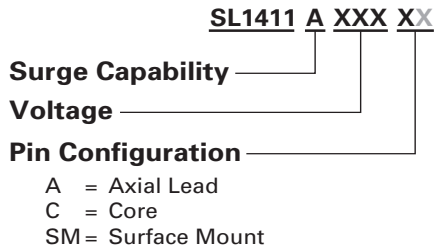



http://littelfuse.com

To assist you with your electronics design and selection processes, Littelfuse also offers:

Comprehensive Online Product Specs on Littelfuse.com—Featuring easy-to-use navigation, search and selection tools, as well as additional product details. You can rely on Littelfuse.com for instant answers and continuously up-to-date information.

Printed Product Catalogs—For offline and off-the-shelf convenience, our printed product catalogs include data sheets, selection tables and tutorials covering all of our core technologies. Contact your Littelfuse product representative or visit www.littelfuse.com/catalogs to check availability.

Circuit Protection Design Guides—Our application design center website, www.littelfuse.com/designcenter, offers a wealth of circuit protection guidance to help you select and apply the best circuit protection solution for your application.

As the world's #1 brand in circuit protection, Littelfuse offers the broadest and deepest portfolio of circuit protection products and a global network of technical support backed by more than 80 years of application design expertise. Visit our design support center to access:

- > Reference Designs
- > Application Notes
- > Application Testing
- > SPICE Models
- > Local Technical Support
- > Product Samples
- > Technical Articles
- > Certification Documents
- > Data Sheets



WWW.LITTELFUSE.COM/DESIGNSUPPORT

Littelfuse offers technologies that protect electronic and electrical circuits and their users against electrostatic discharge (ESD), load switching surges, lightning strike effects, overloads, short circuits, power faults, ground faults and other threats.

Overcurrent Protection Products:

Fuses Littelfuse offers the world's broadest range of fuse types and ratings, including cartridge, leaded, surface mount and thin film designs

PTCs Positive Temperature Coefficient thermistor technology provides resettable current-limiting protection

Protection Relays Electronic and microprocessor-based protection relays minimize damage to equipment and personnel caused by electrical faults

Overvoltage Protection Products:

Varistors Littelfuse offers surface mount Multi-Layer Varistors (MLVs) and industrial Metal Oxide Varistors (MOVs) to protect against transients

GDTs Gas Discharge Tubes (GDTs) to dissipate transient voltage through a contained plasma gas

Thyristors Solid state switches that control the flow of current in a wide range of appliances, tools and equipment

SIDACTor® Devices Overvoltage protection specifically designed for legacy telecom and today's broadband connections

TVS Diodes Silicon Transient Voltage Suppression (TVS) devices

SPA™ Silicon Protection Arrays designed for analog and digital signal line protection

PulseGuard® ESD Suppressors Small, fast-acting Electrostatic Discharge (ESD) suppressors

Special Application Products:

PLED LED Protectors LED string reliability devices that offer open LED bypass, ESD protection and reverse connection protection

Download catalogs at www.littelfuse.com/catalogs or contact your authorized Littelfuse product representative for more information.

